

EXTENDING MODULAR PNML TO COVER HIGH-LEVEL FEATURES

Alexis Marechal
University of Geneva



MeFoSyLoMa workshop
15/06/12

Outline

Outline



Scope

Outline



Scope

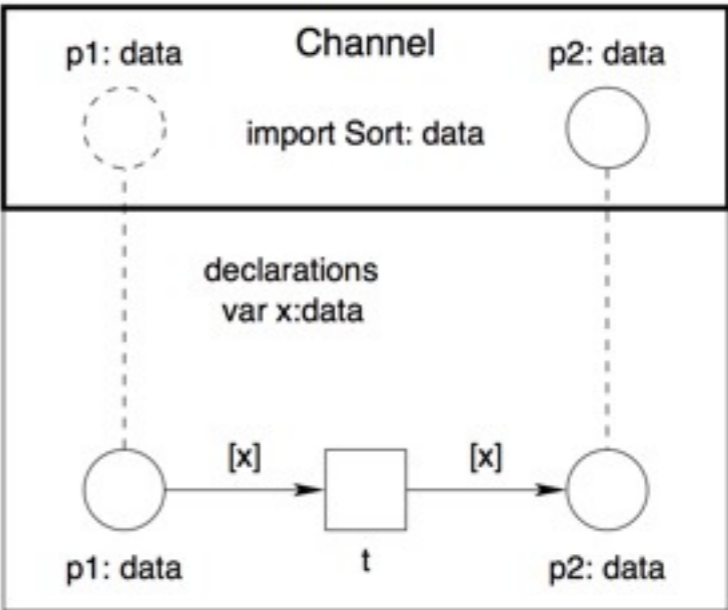

Outline



Scope

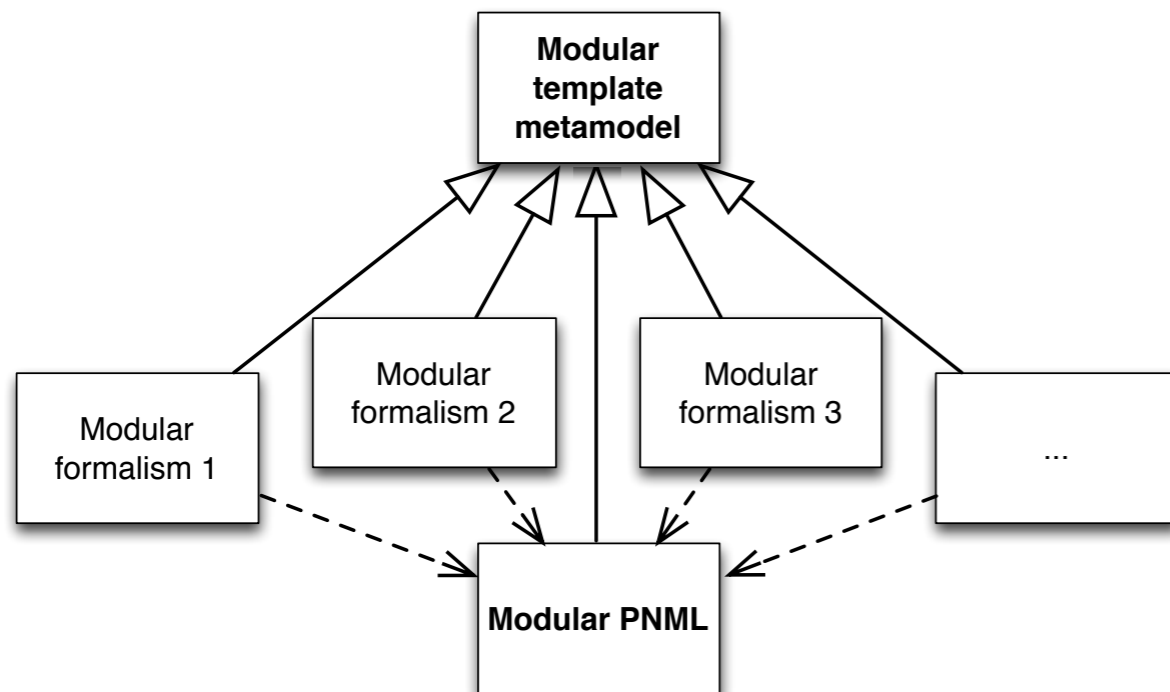
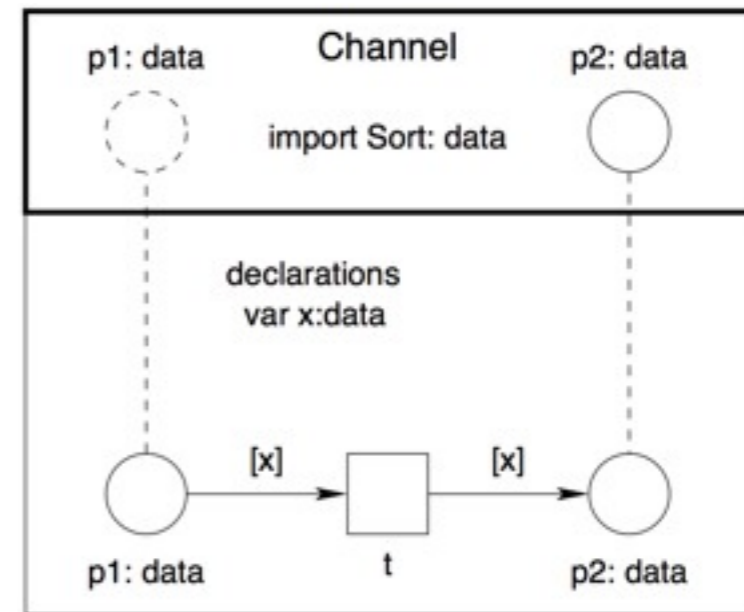

Methodology

Outline



Scope

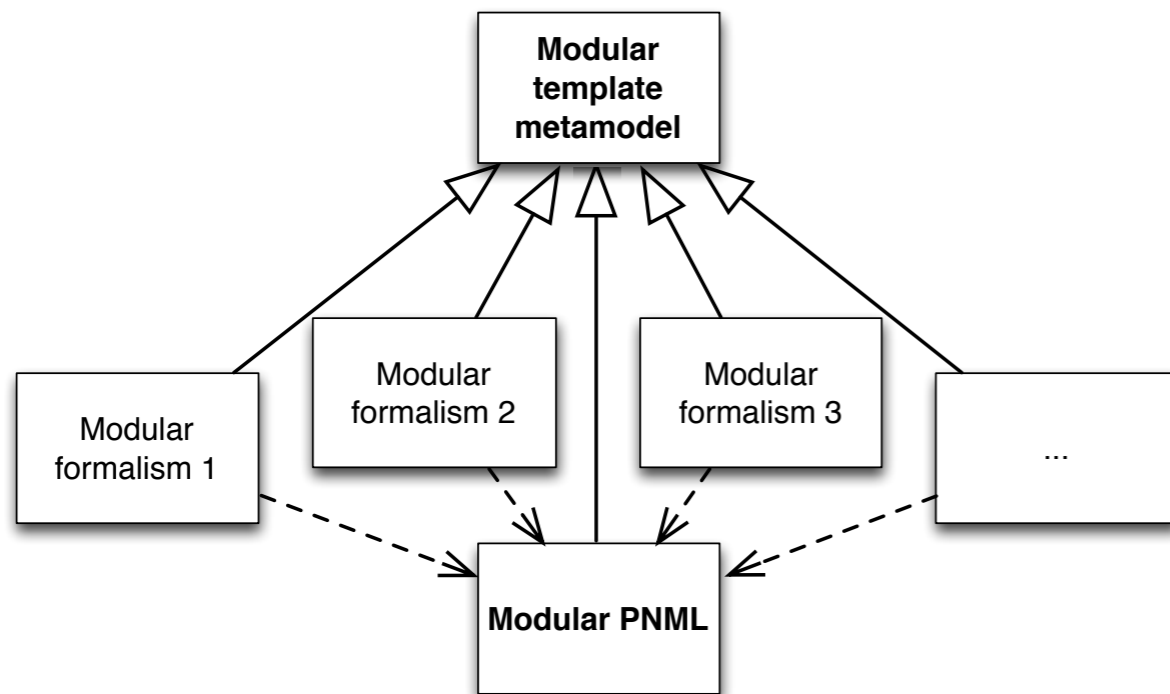
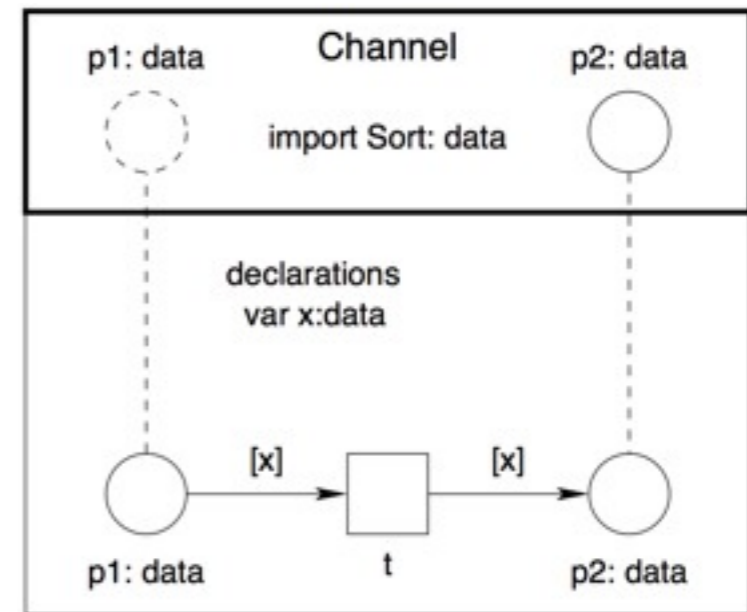

Methodology

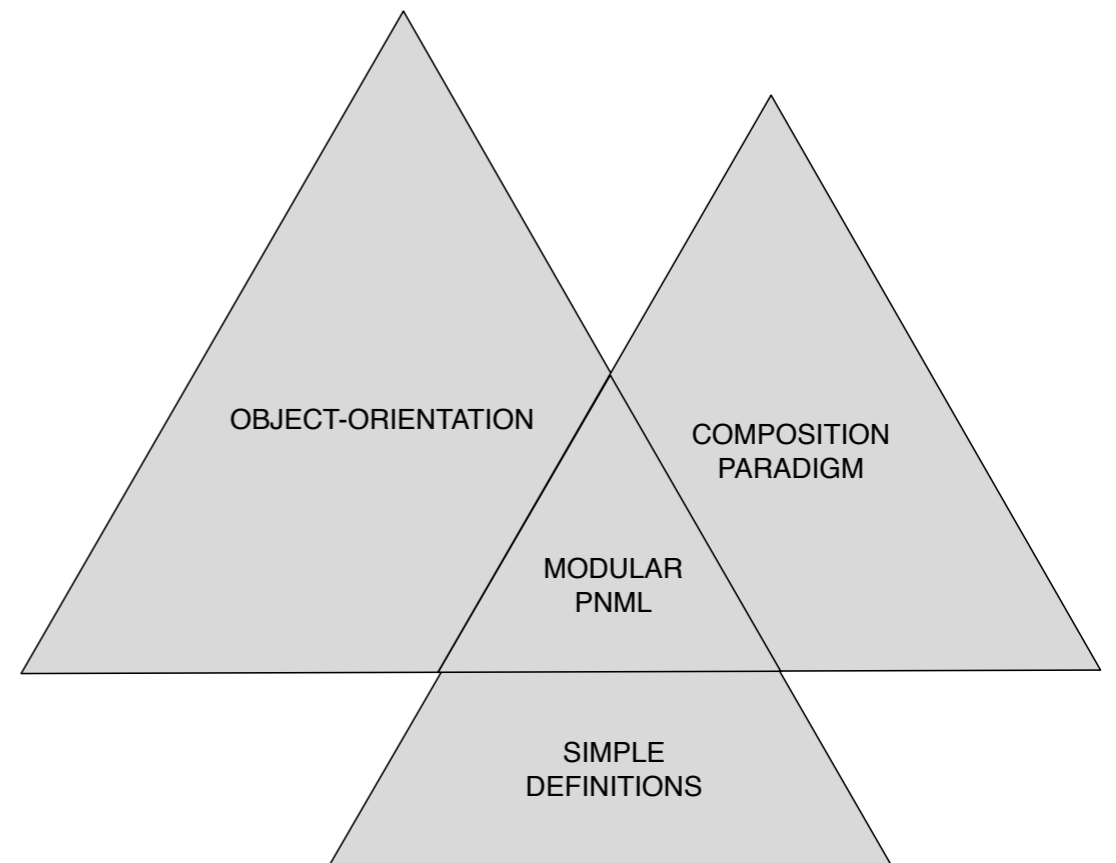

Extensions

Outline



Scope

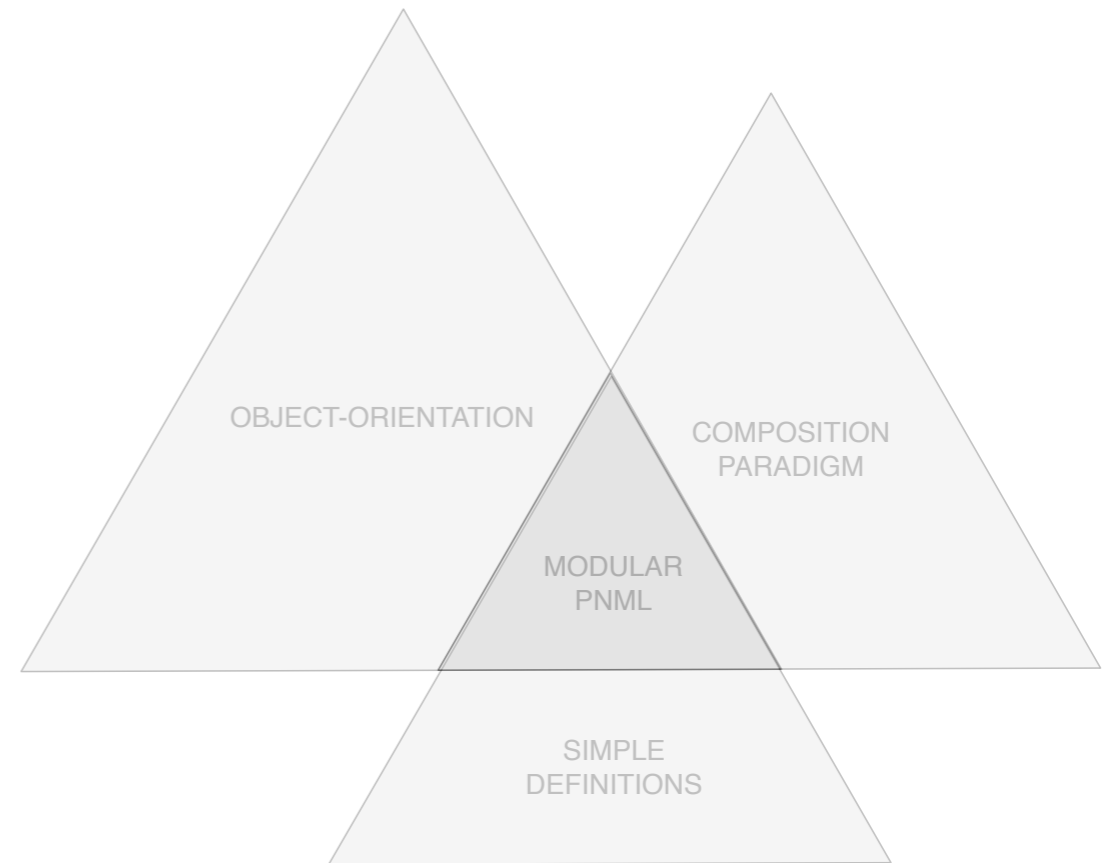
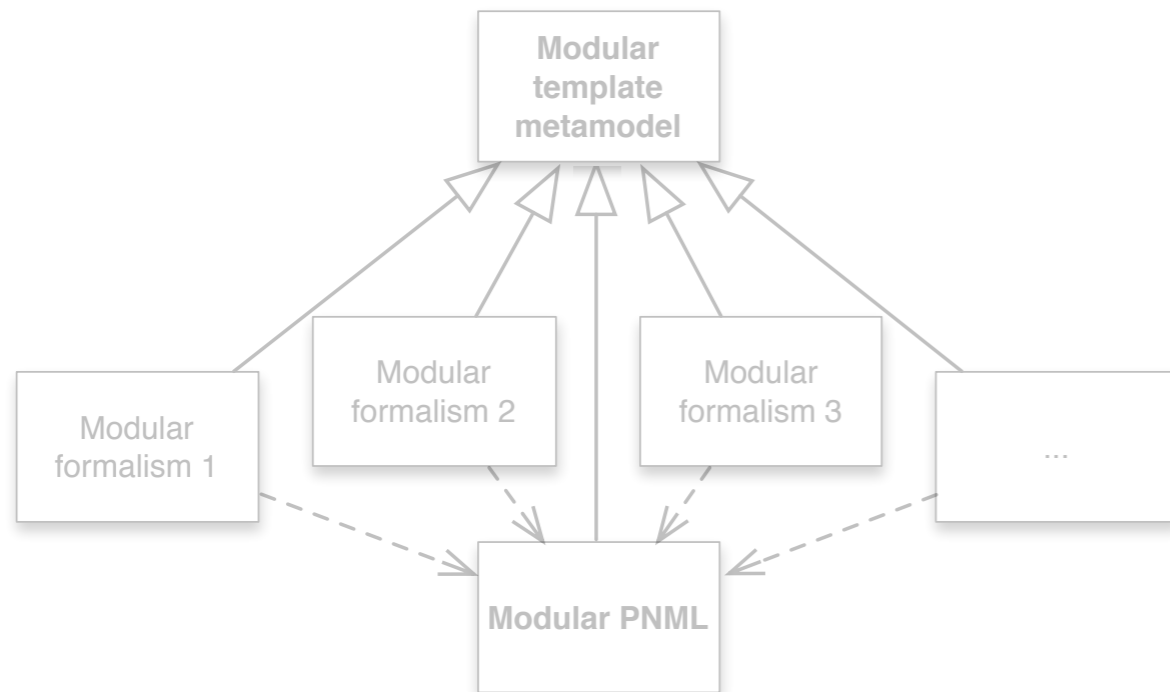
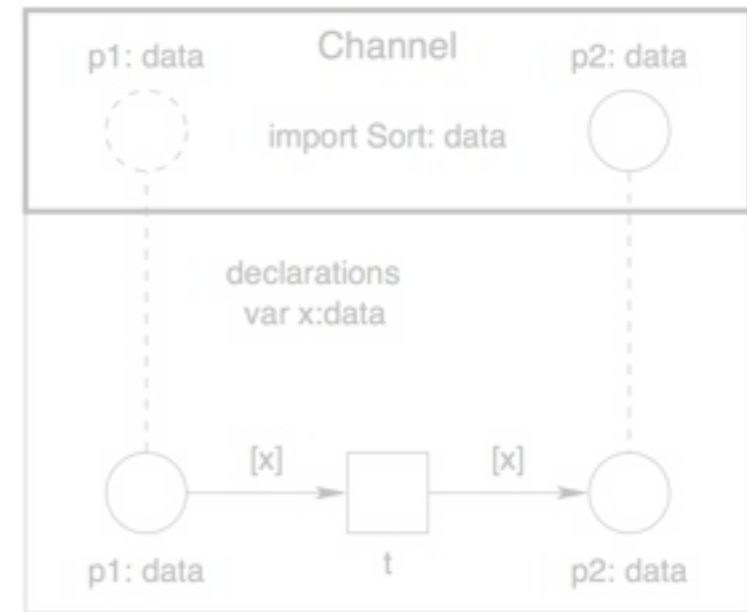



ISO-IEC 15909



ISO-IEC 15909

Part 1: Definitions



ISO-IEC 15909

Part 1: Definitions

Part 2: PNML

Part 2: PNML

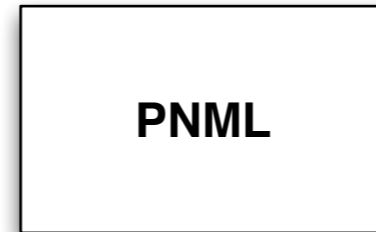

Part 2: PNML

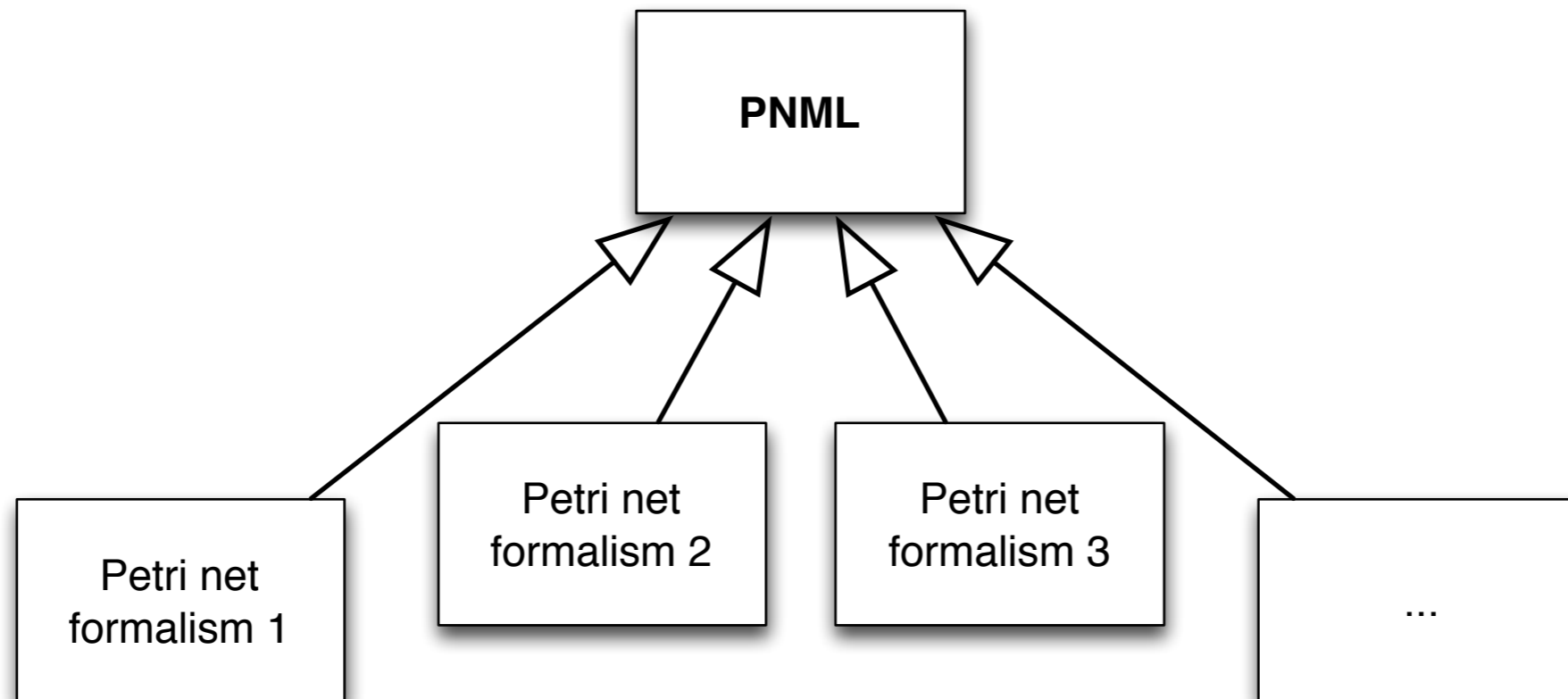

Part 2: PNML

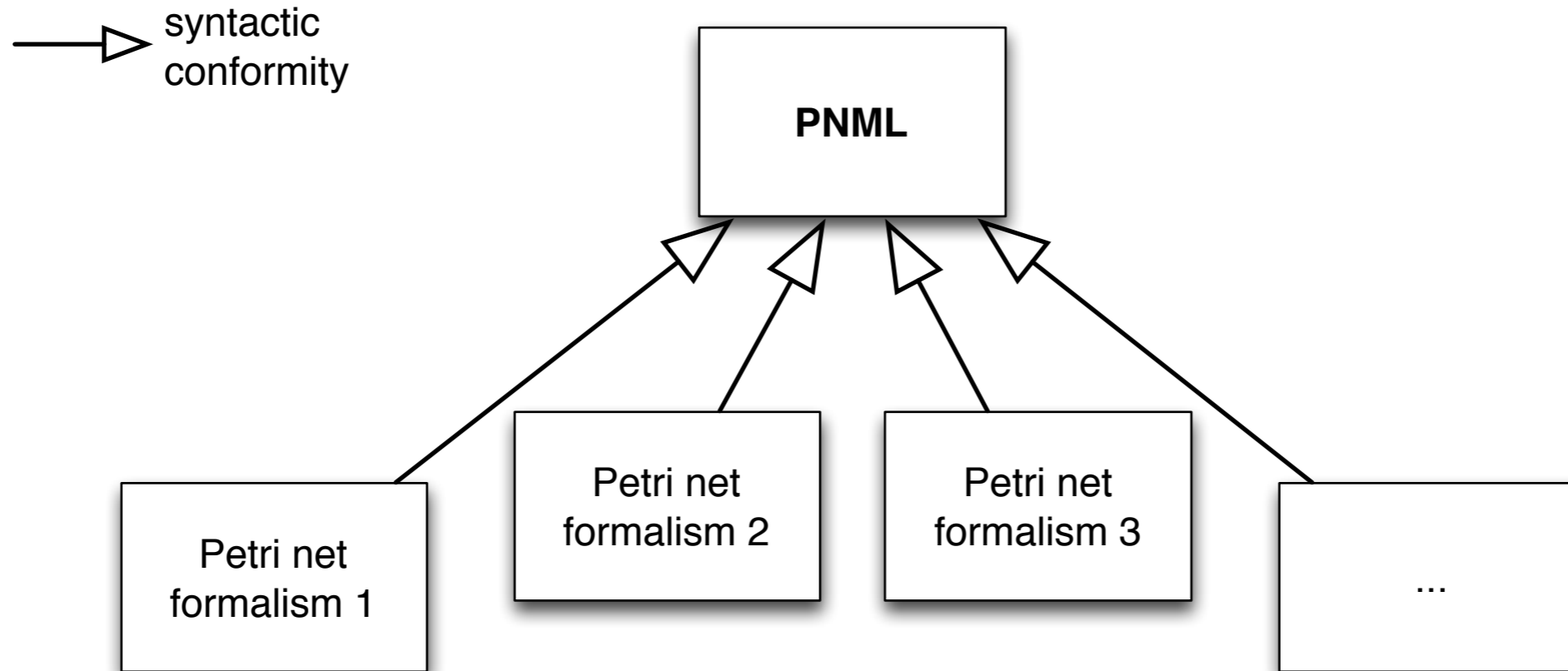

Part 2: PNML

→ syntactic conformity

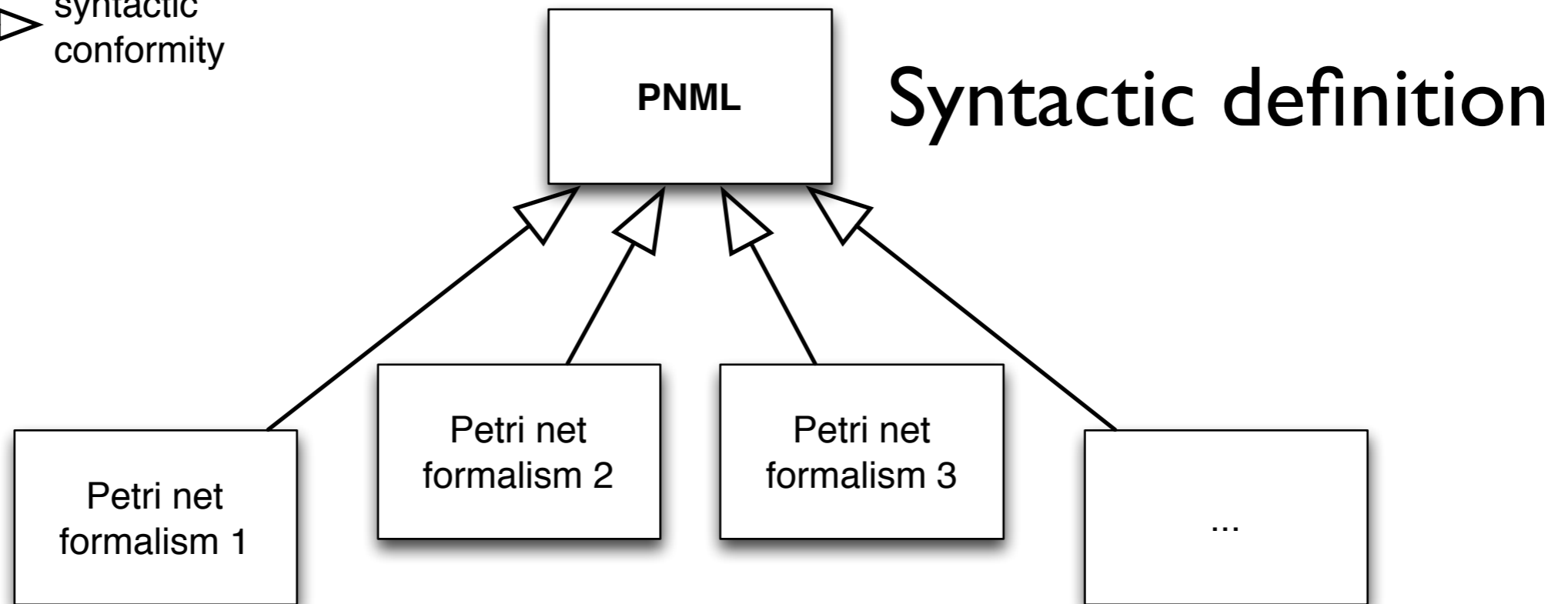



ISO-IEC 15909

Part 1: Definitions

Part 2: PNML



ISO-IEC 15909

Part 1: Definitions

Part 2: PNML

Part 3: Extensions

Part 3: Extensions

Part 3: Extensions

Probabilities

Time

Modularity

Priorities

Part 3: Extensions

Probabilities

Time

Modularity

Priorities

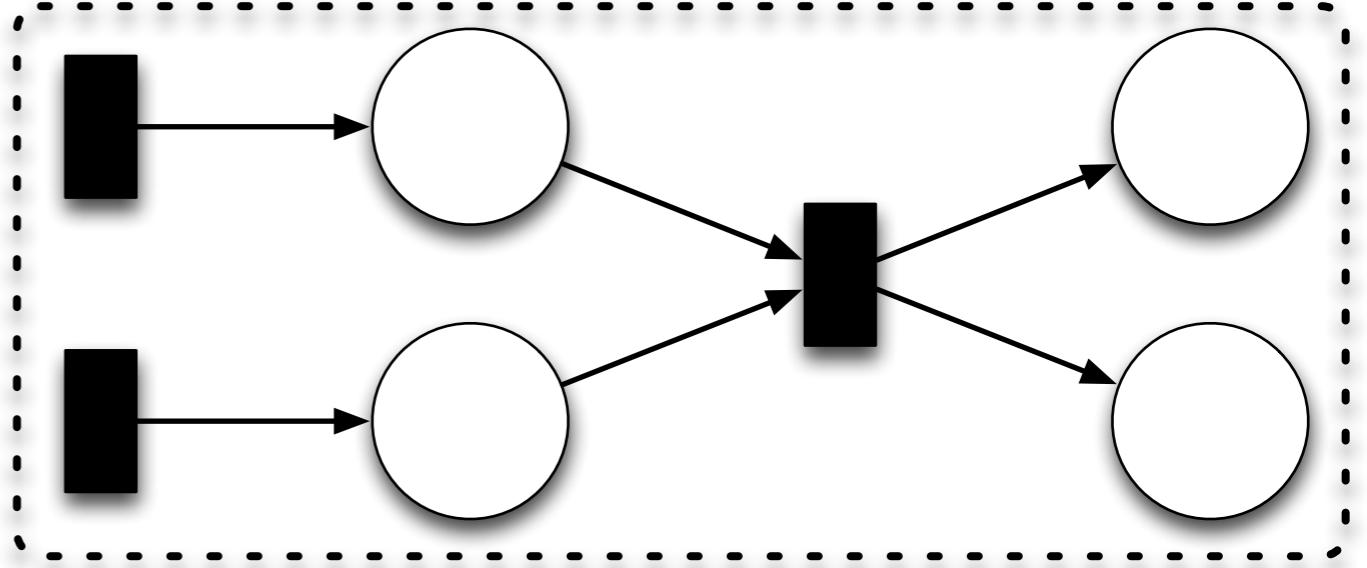
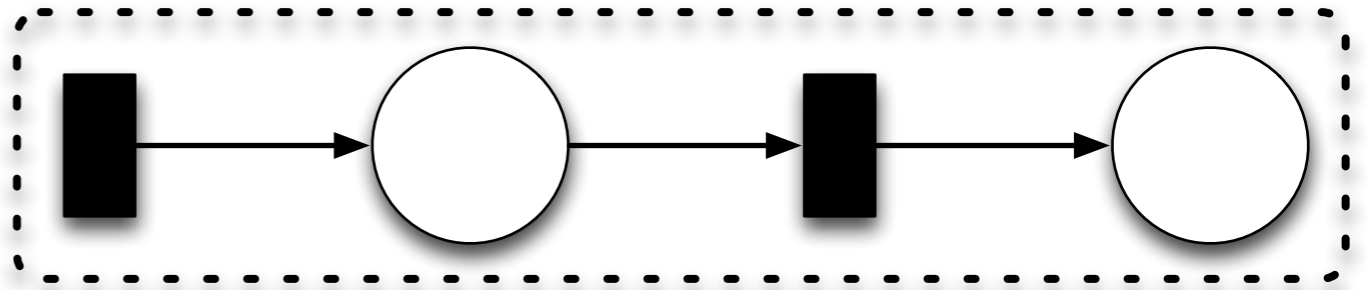
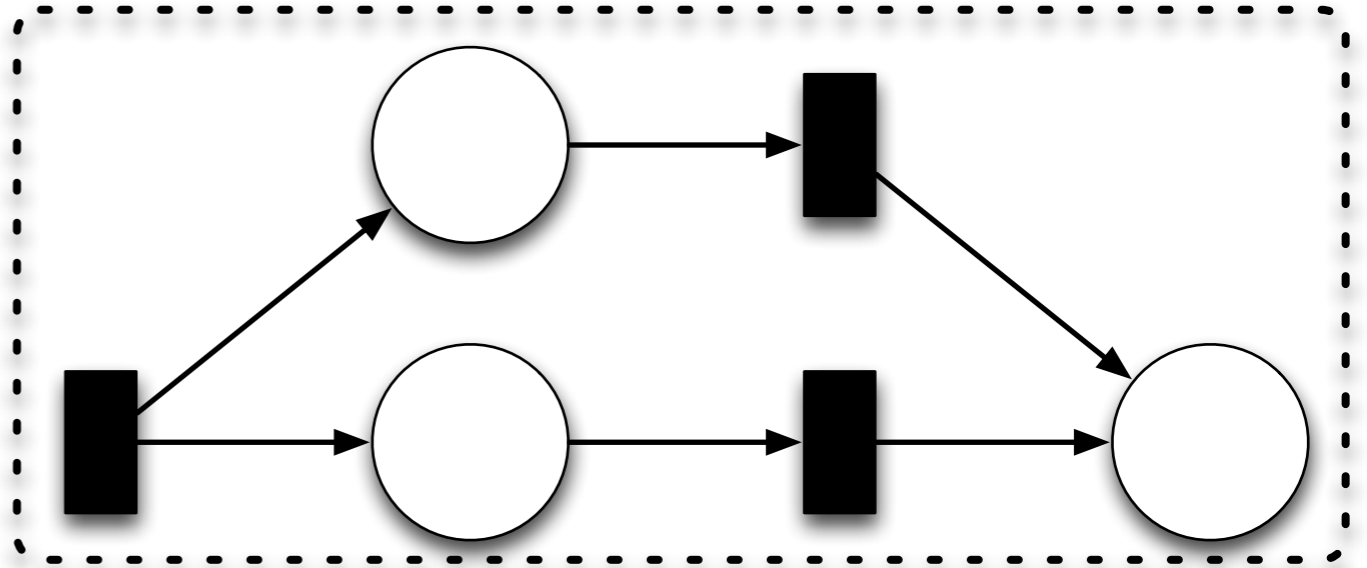
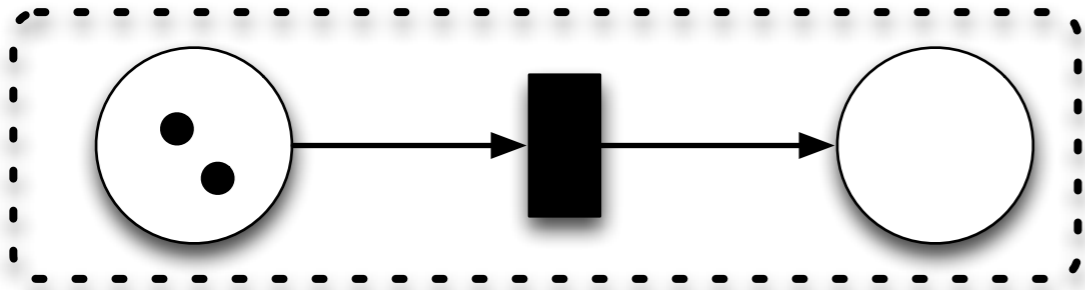

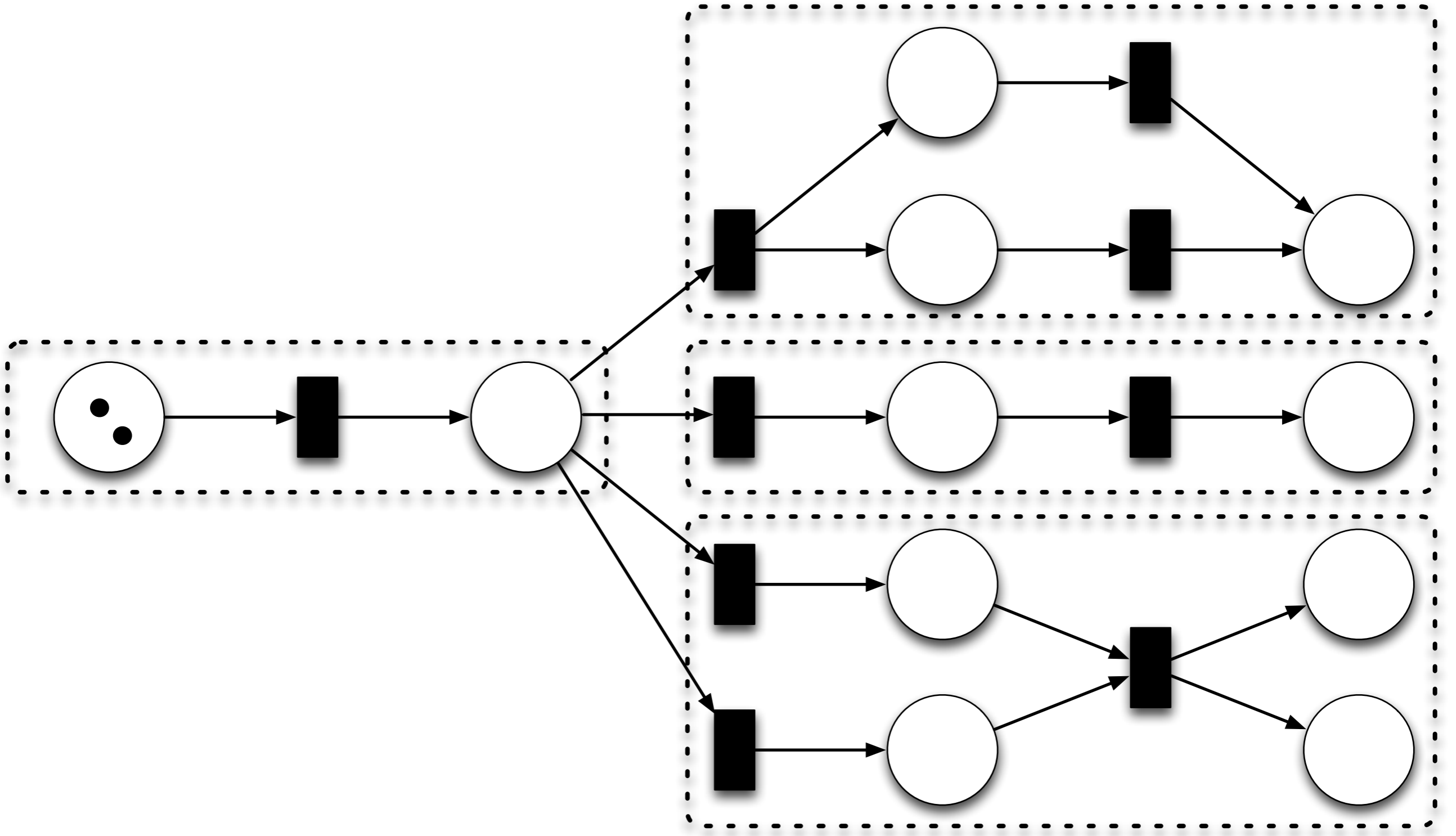

2) TÂCHES

MAPPING SÉMANTIQUE (MILAN)

- MODULARITE (Buccho + Petrucci) + TREVES
- TEMPS (Béland + Lime)
- APN (Paréchal + PETRUCCI)
- PRIORITE (Petrucci + Lakos)
- PROBA(?) (François Robert, "Les systèmes d'urgence distribués")

LE MANIÈRE {

- TACHONNEMENT
- POLITIQUE DE ROUTE
- POLITIQUE DE RENDE

 } CORON + LIMAD

SOTA + PROPAL POUR ADAPTABILITE

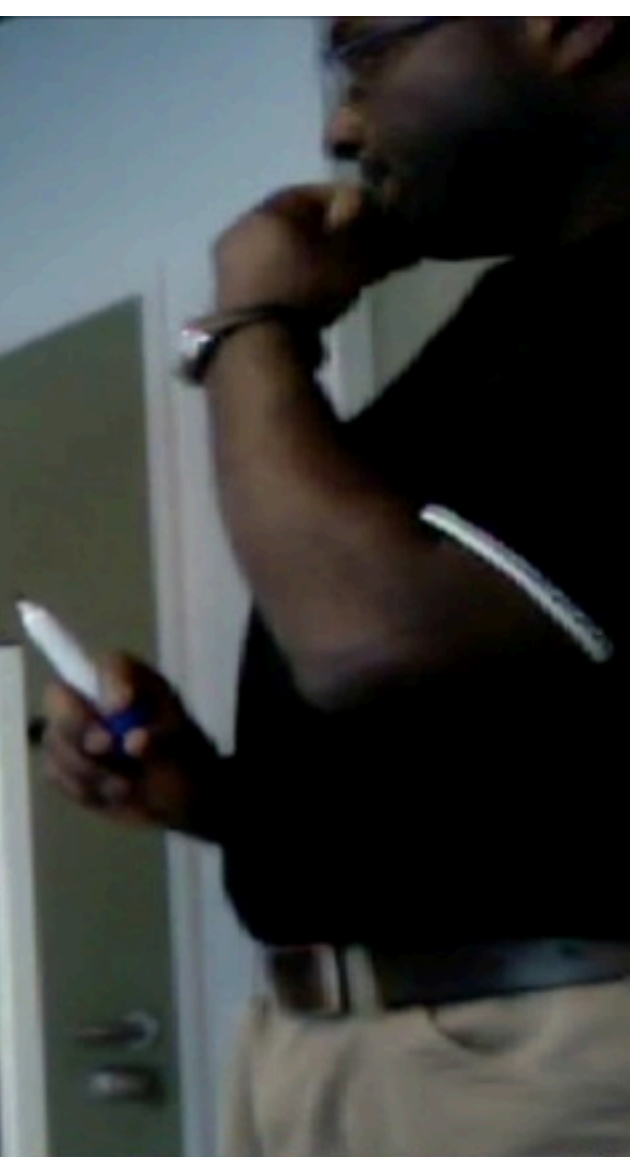

2) TÂCHES

MAPPING SÉMANTIQUE (MILAN)

MODULARITÉ (Buccho + Petrucci)

- TEMPS (Betand + Lime)
- APN (Paréchal + Petrucci)
- PRIORITÉ (Petrucci + Lakos)
- PROBA(?)

(François Robert, "Les systèmes d'urgence distribués")

LE MANIÈRE

- TRAITEMENT
- POLITIQUE DE ROUTE
- POLITIQUE DE RENDE

COORDON + LIMBARD

SOTA + PROPAL POUR ADAPTABILITÉ



Outline



Scope

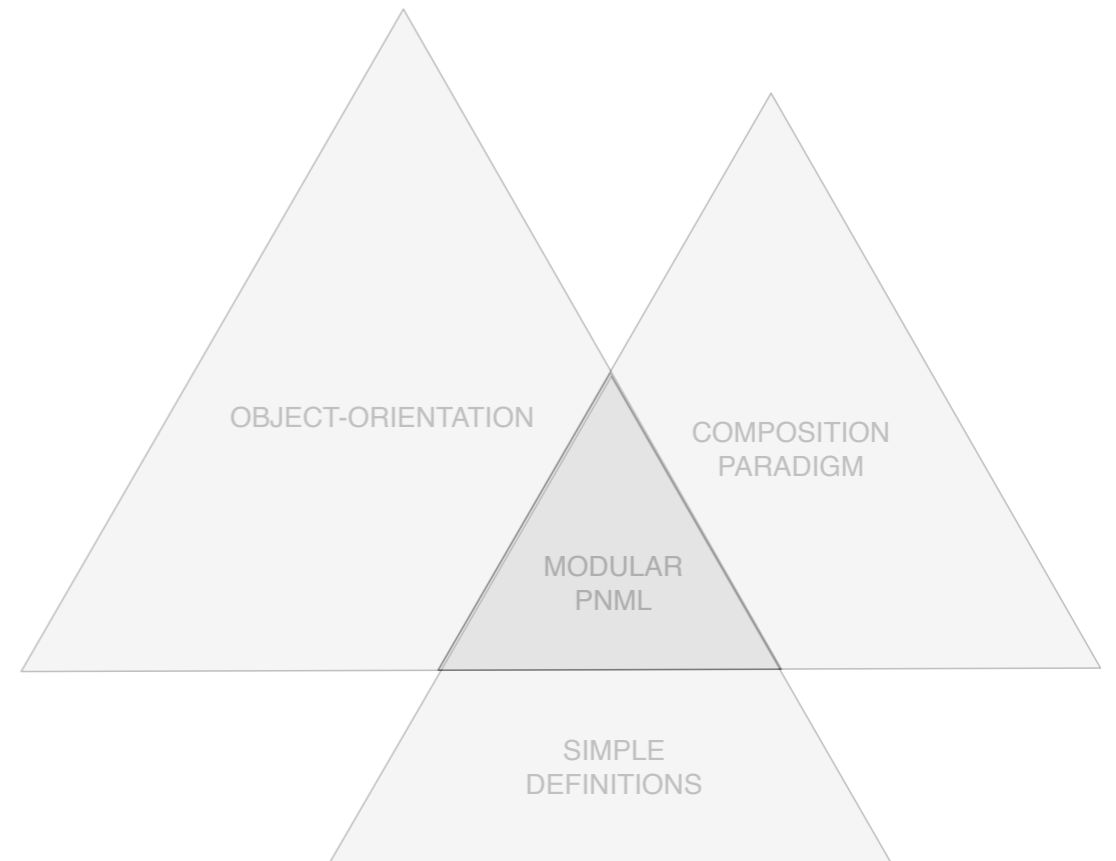
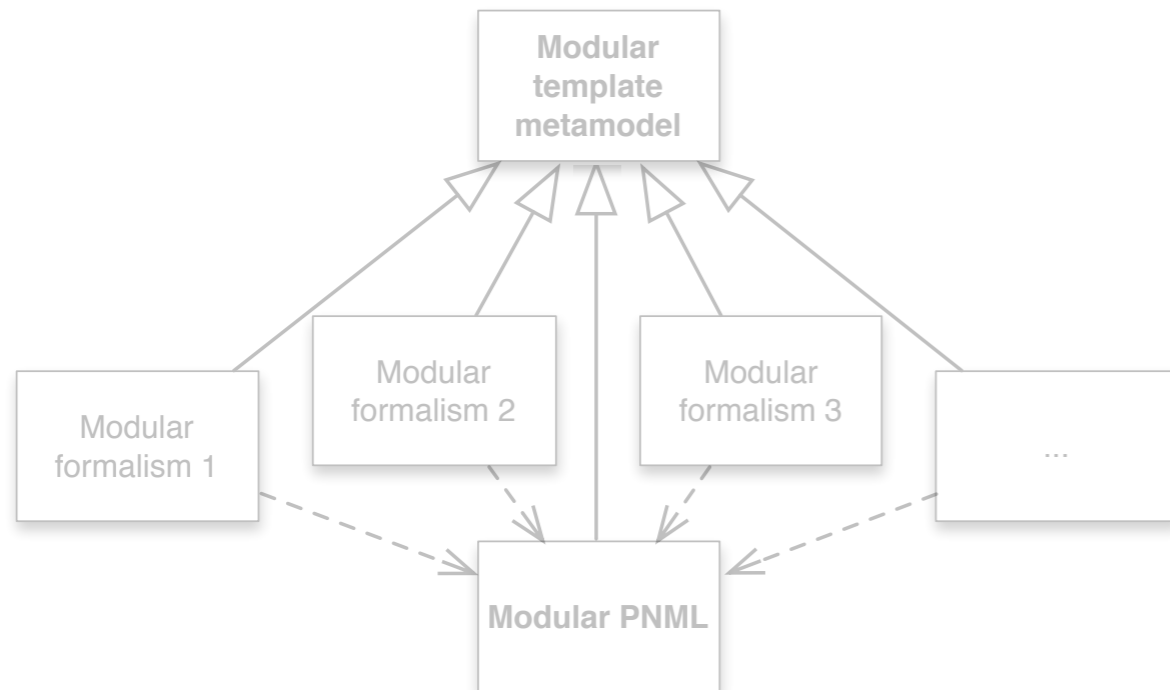
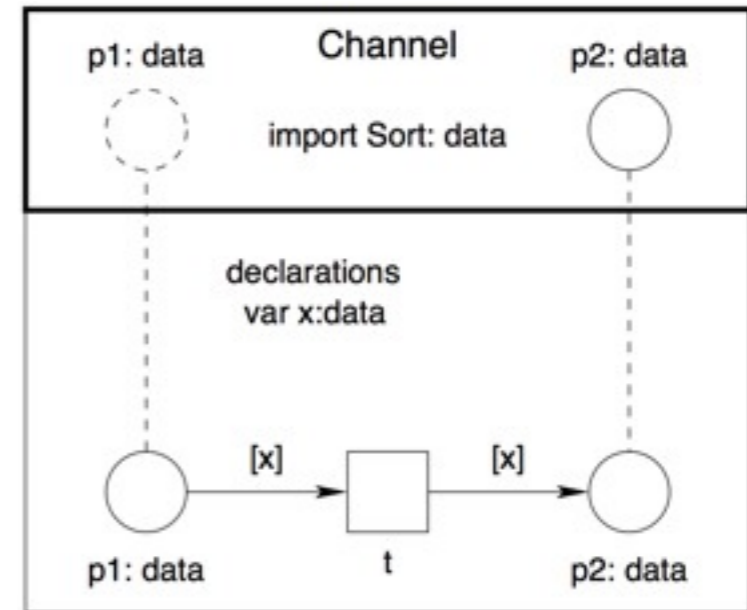

Modular PNML

Kindler, Petrucci, 2009,
Towards a Standard for Modular Petri Nets: A Formalisation

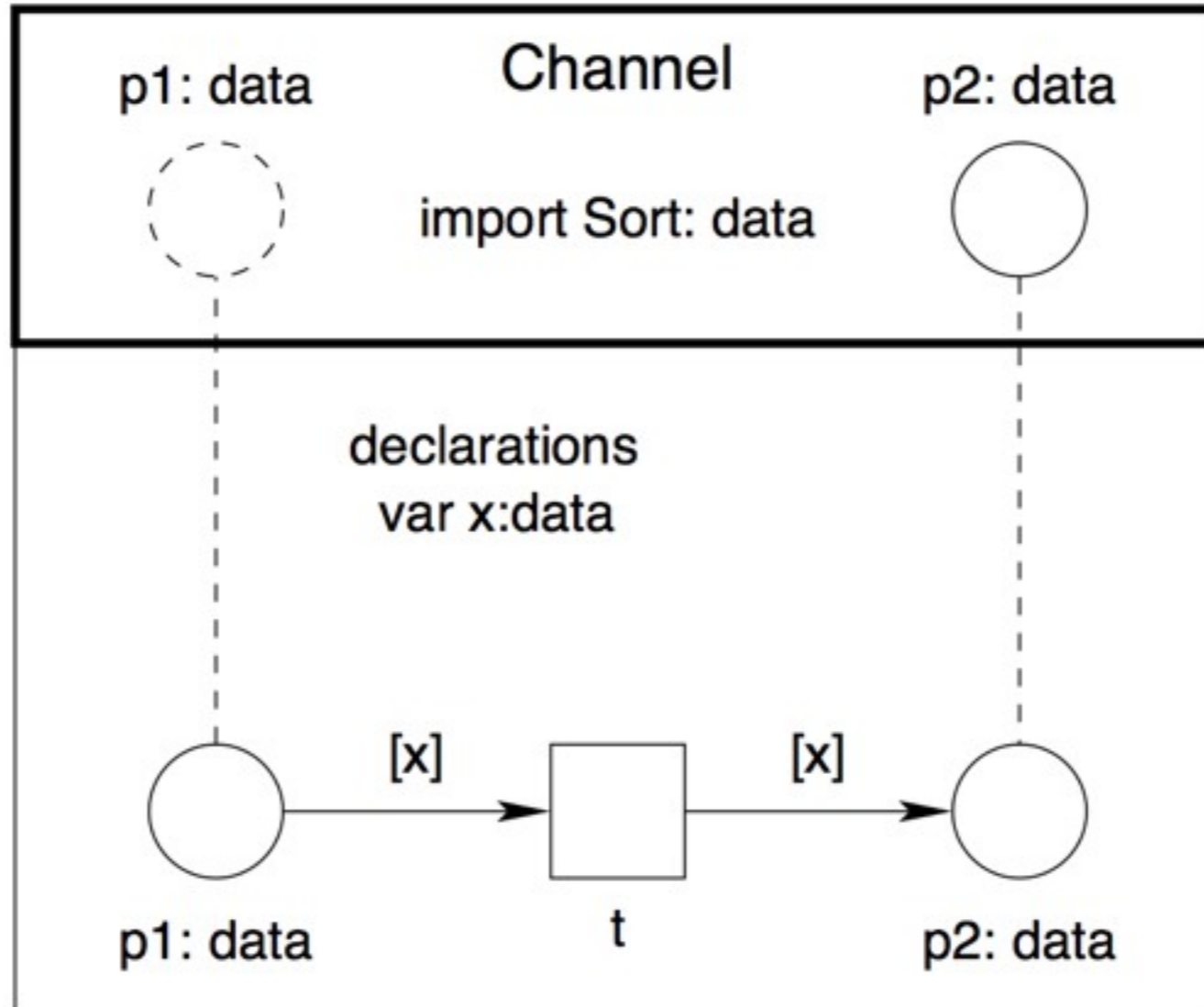

★ Image taken from the original article

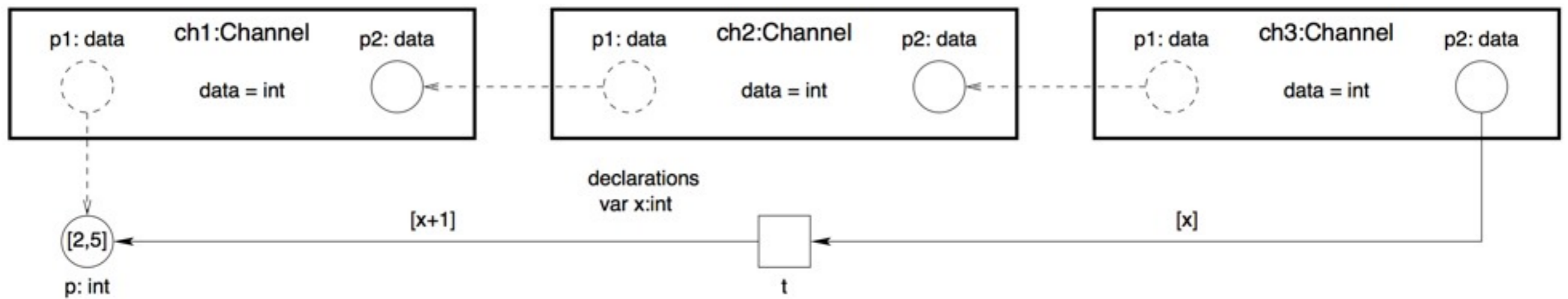

★ Kindler, Petrucci, 2009,
Towards a Standard for Modular Petri Nets: A Formalisation

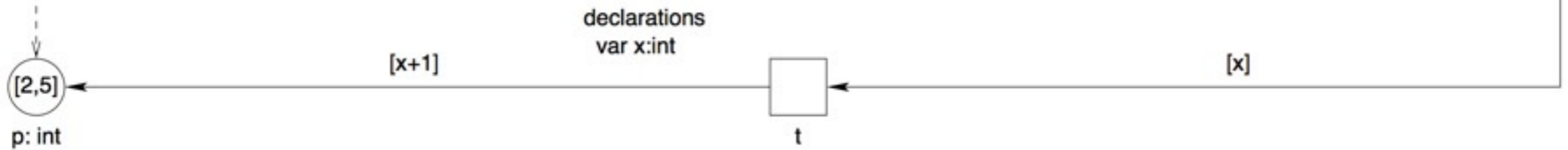
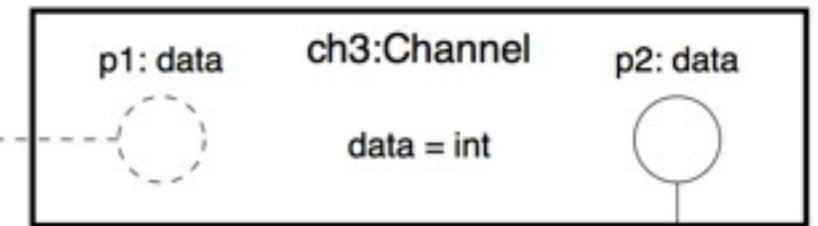
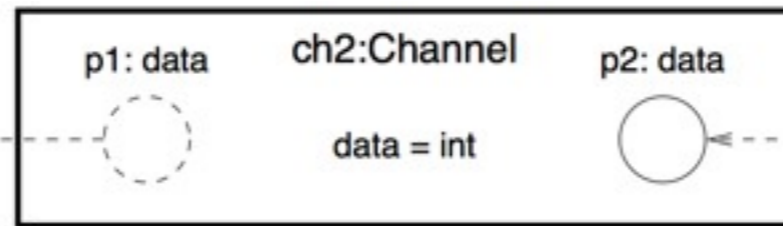
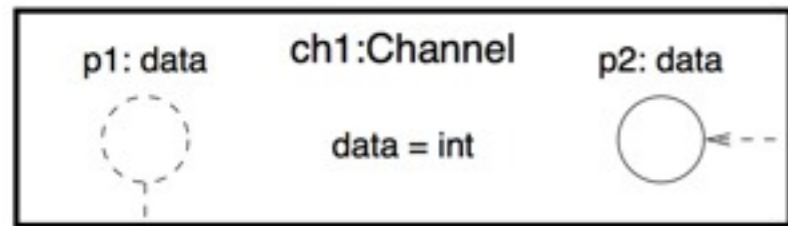
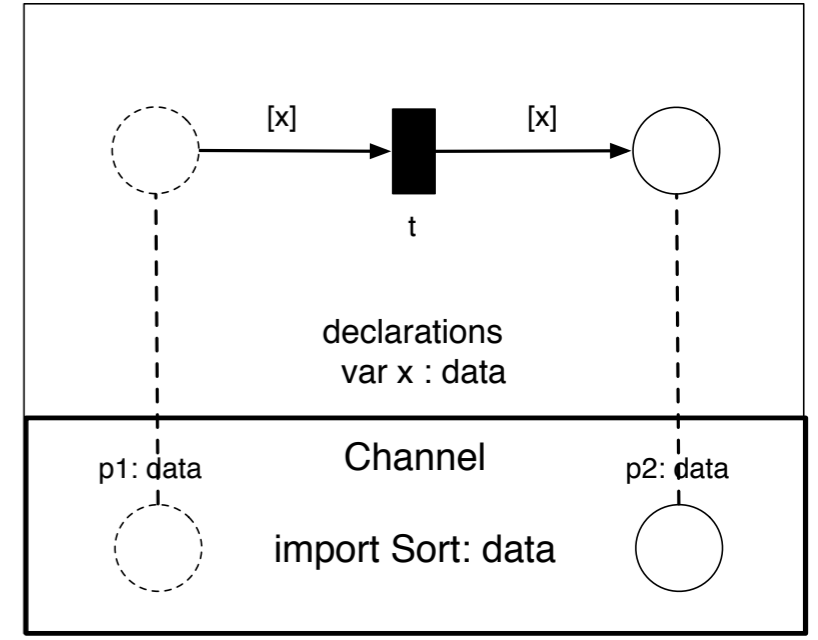
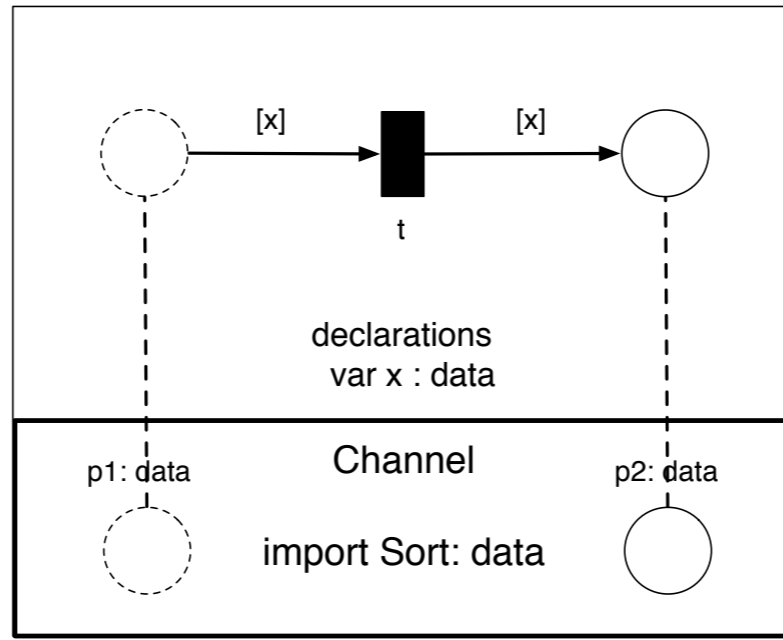
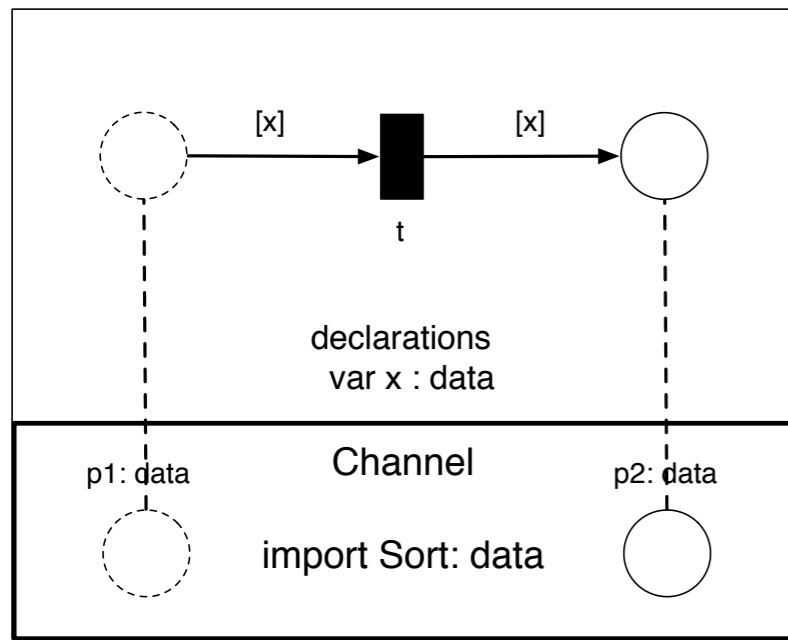

Kindler, Petrucci, 2009,
Towards a Standard for Modular Petri Nets: A Formalisation

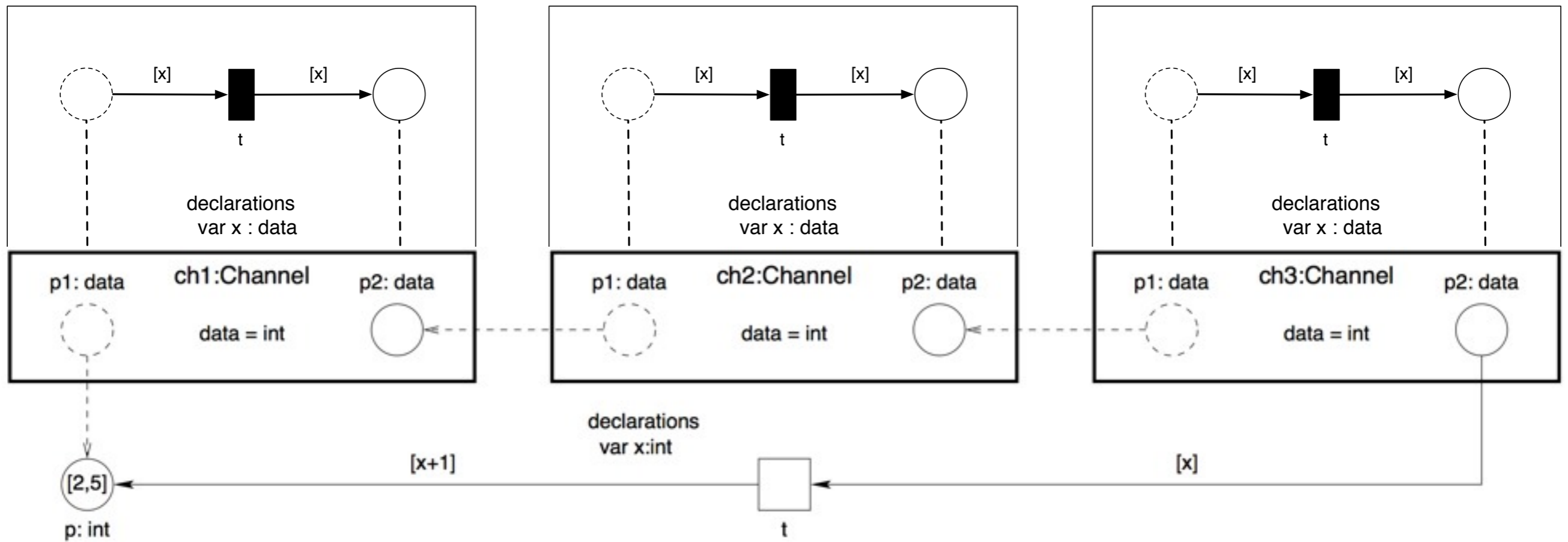

Kindler, Petrucci, 2009,
Towards a Standard for Modular Petri Nets: A Formalisation

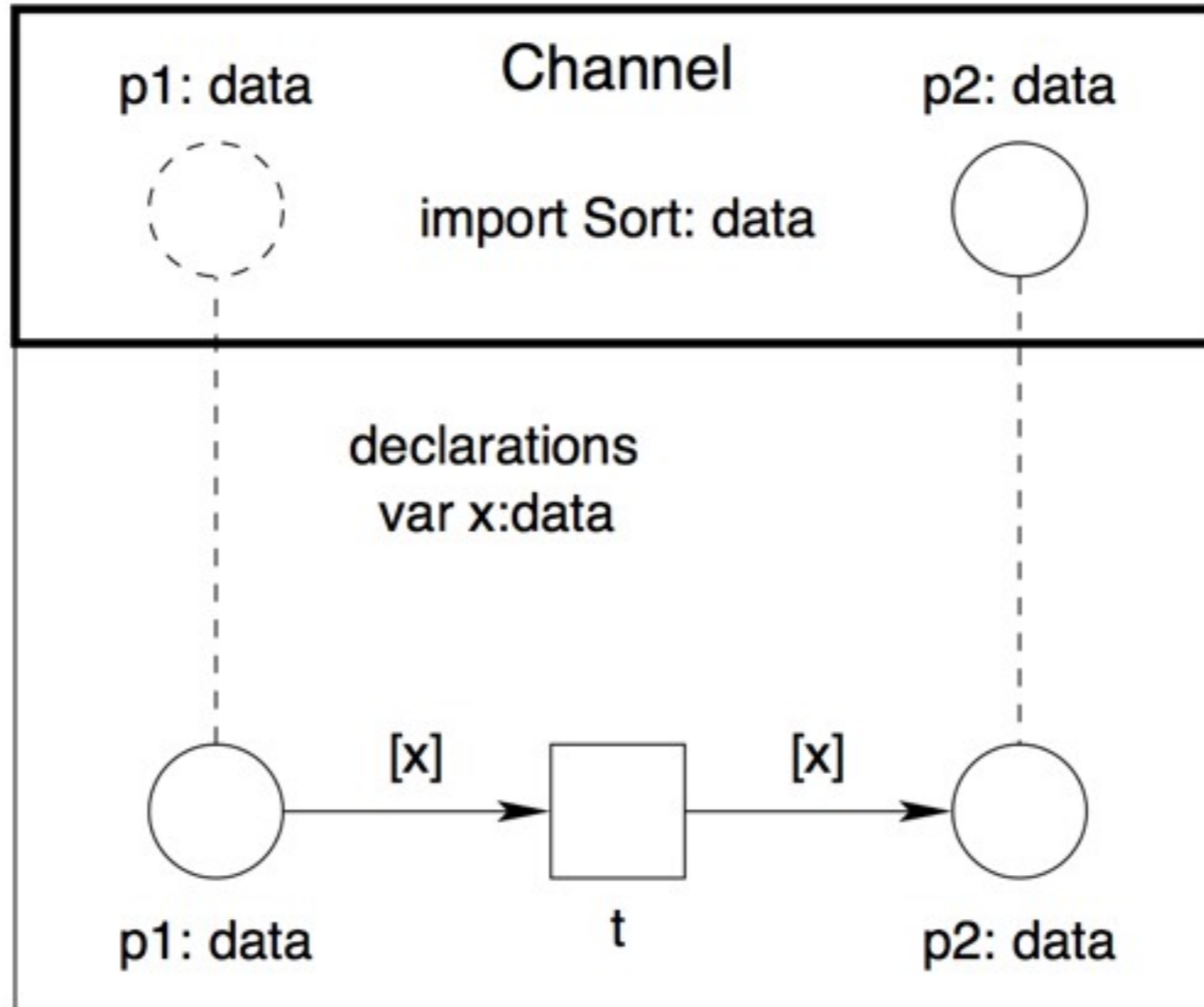

★ Image taken from the original article

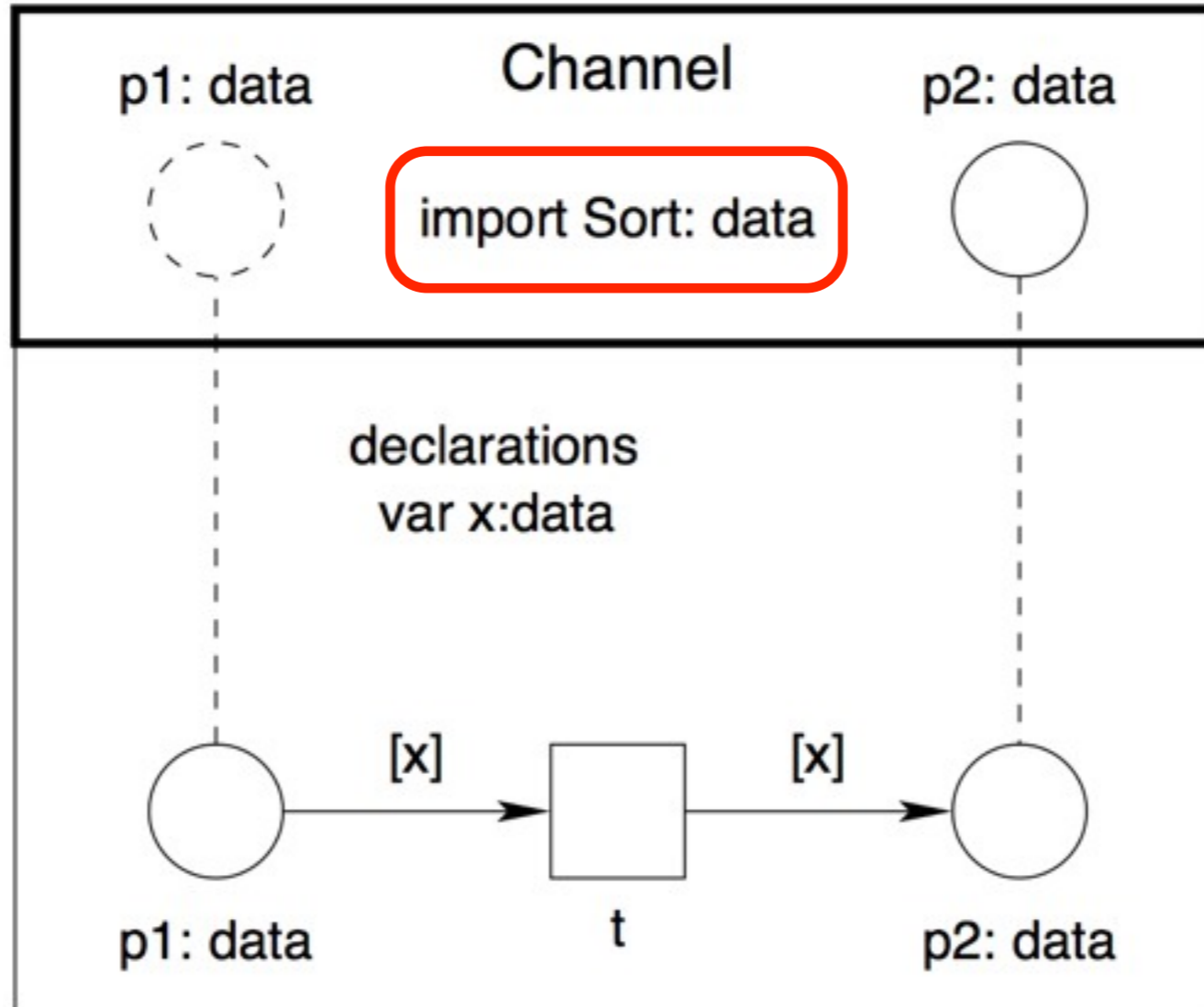

→ syntactic conformity

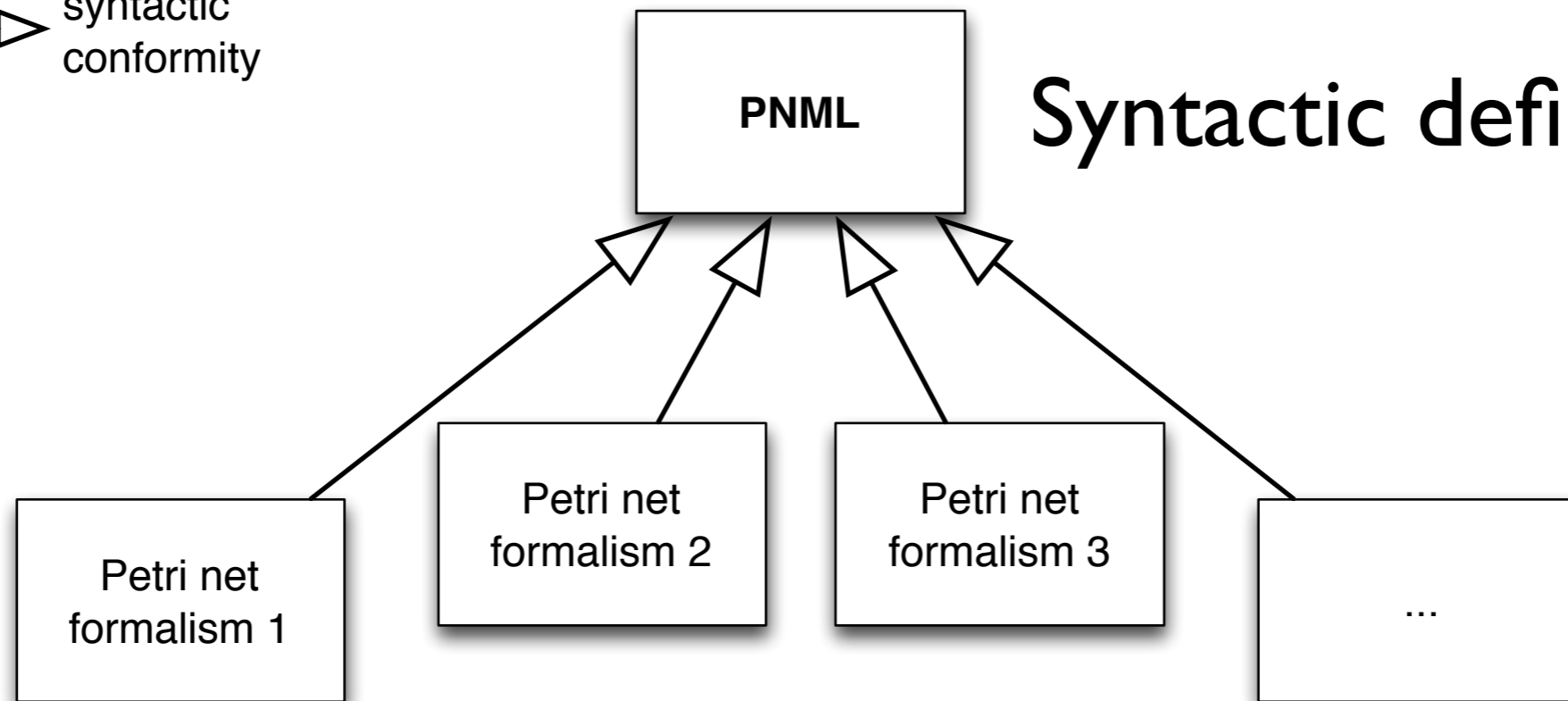

PNML

Syntactic definition

PNML

Syntactic definition

Modular PNML

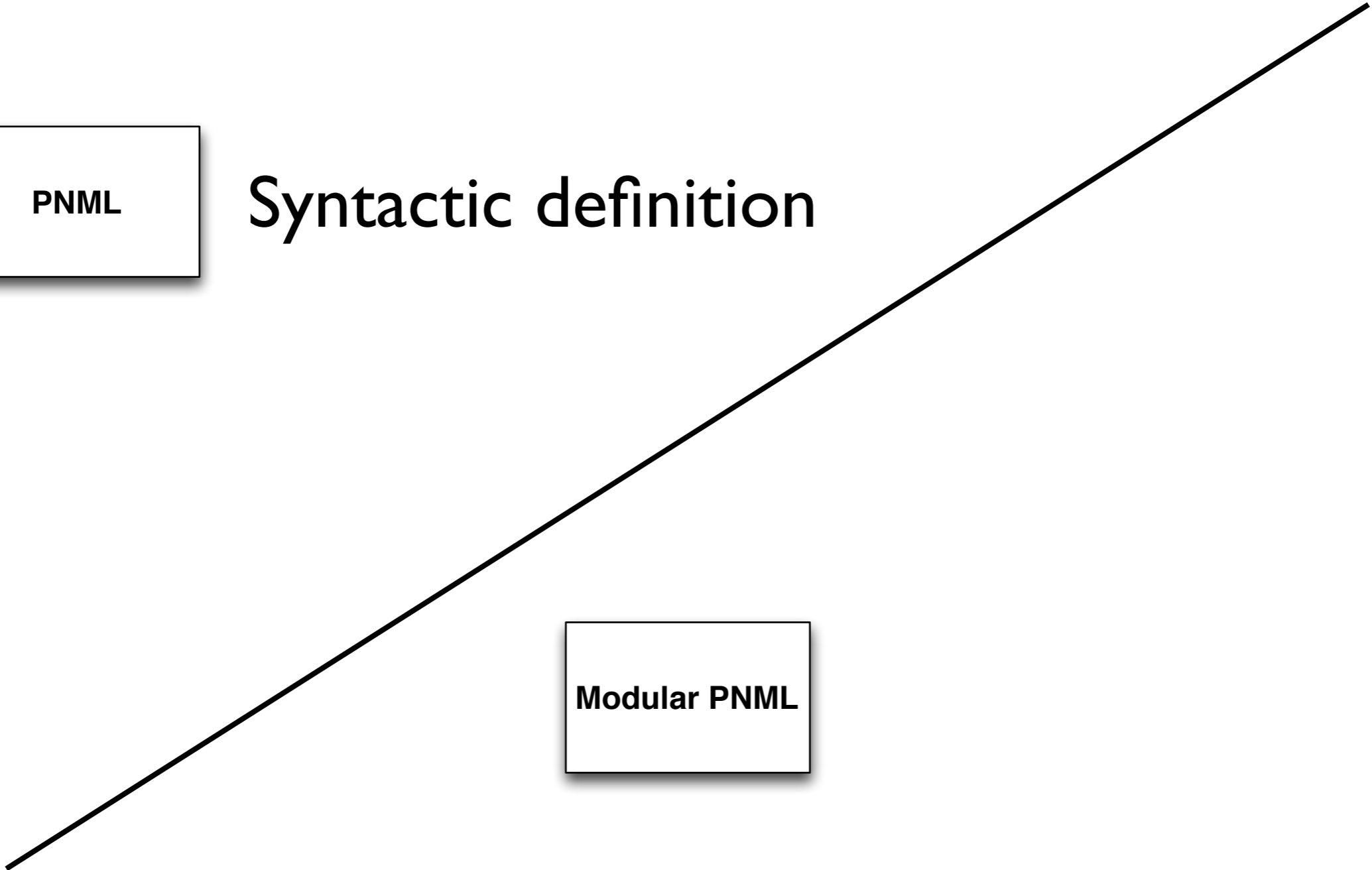

PNML

Syntactic definition

Modular PNML

Semantic platform

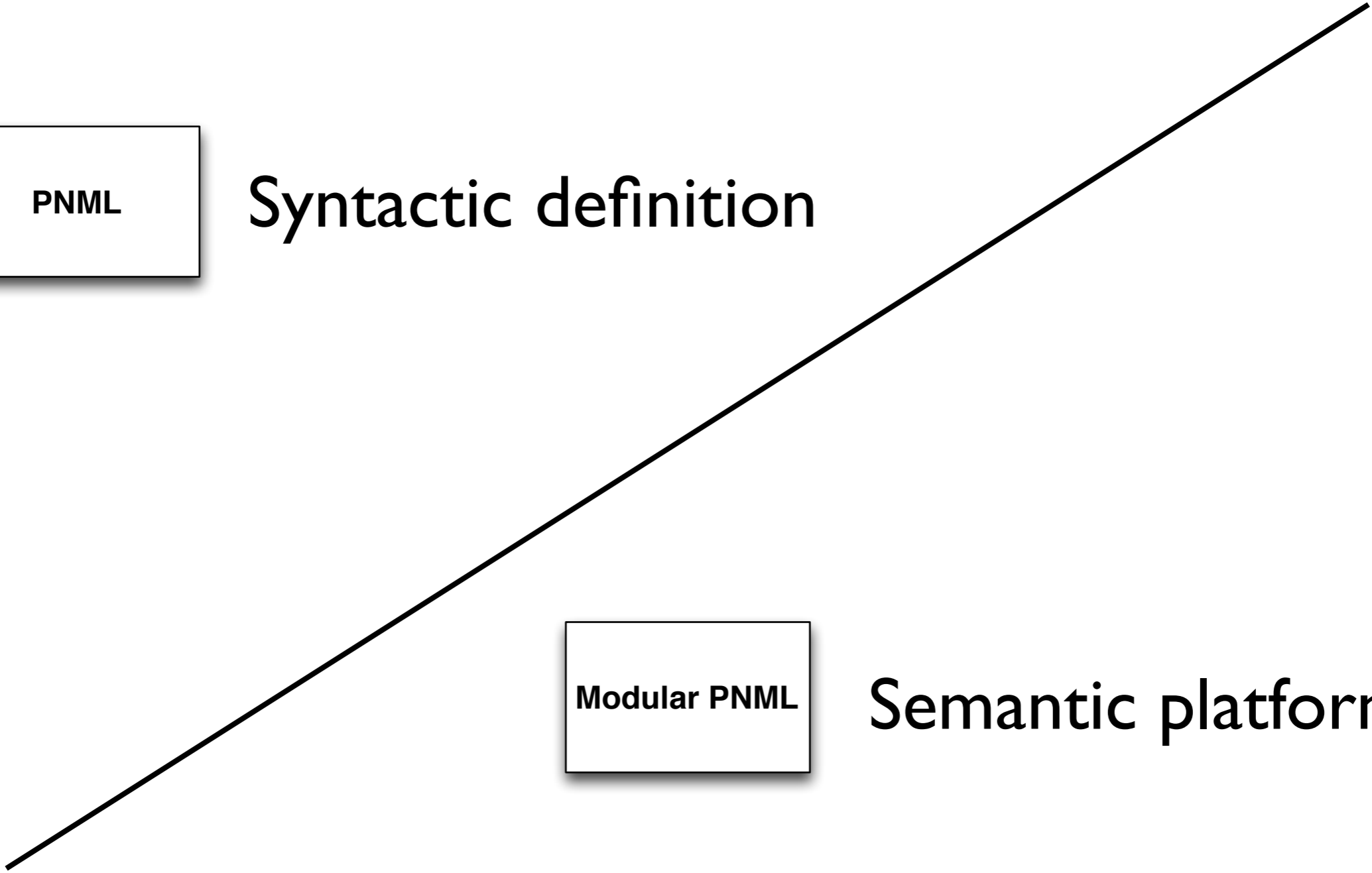

Outline

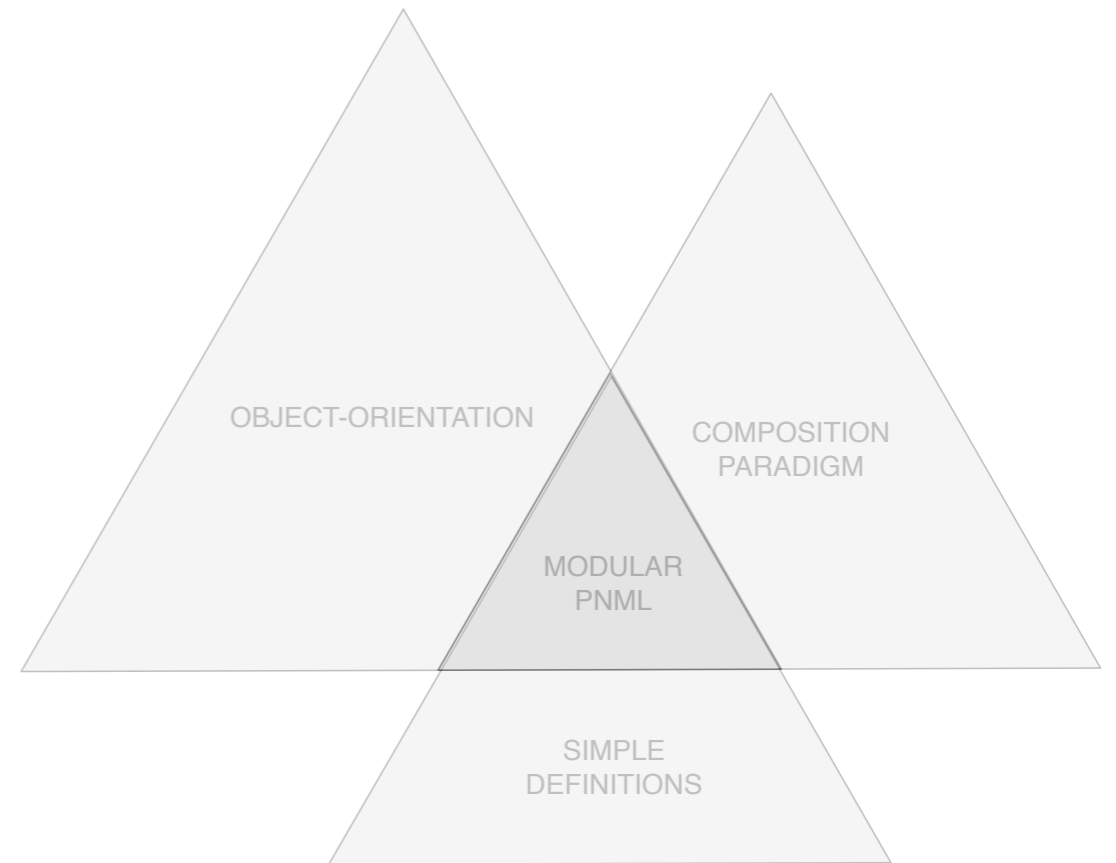
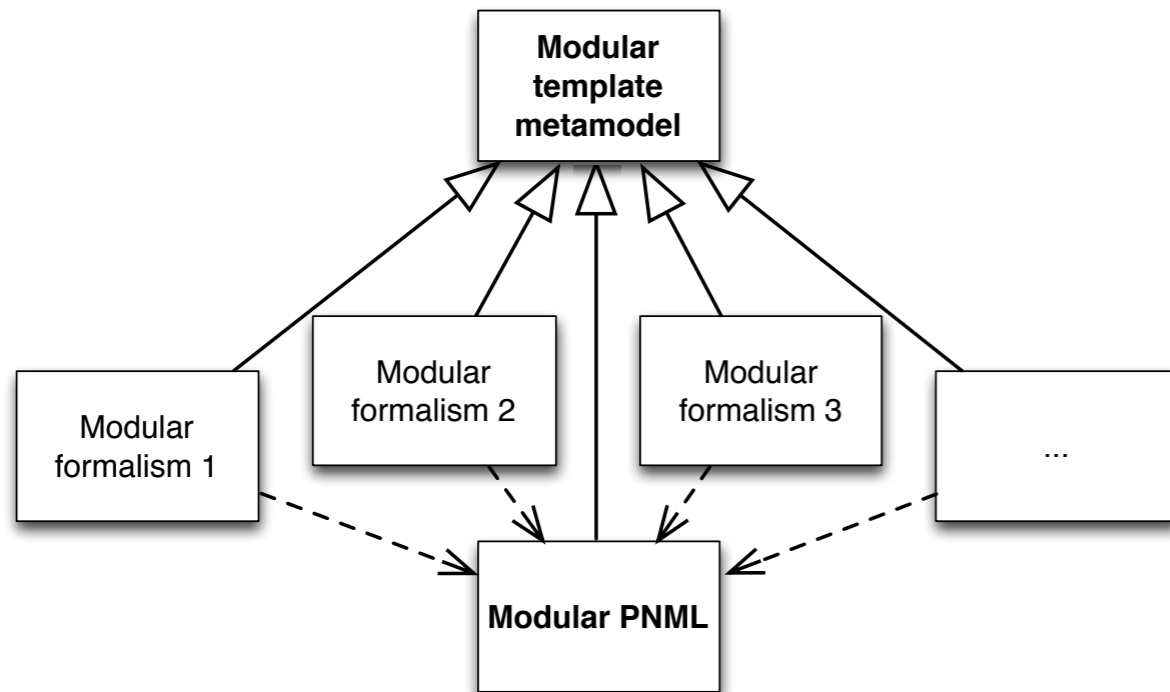
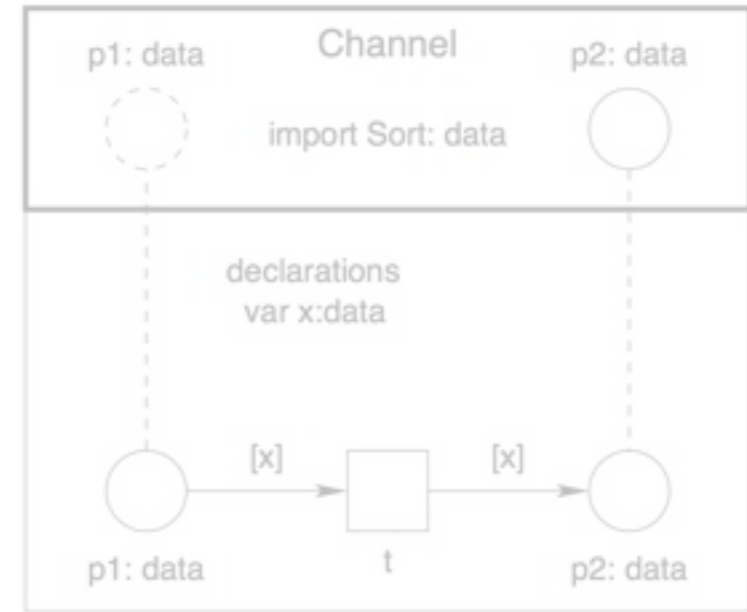

Methodology

Modular PNML

Semantic platform

**Modular
template
metamodel**

Syntactic definition

Modular PNML

Semantic platform

→ syntactic conformity

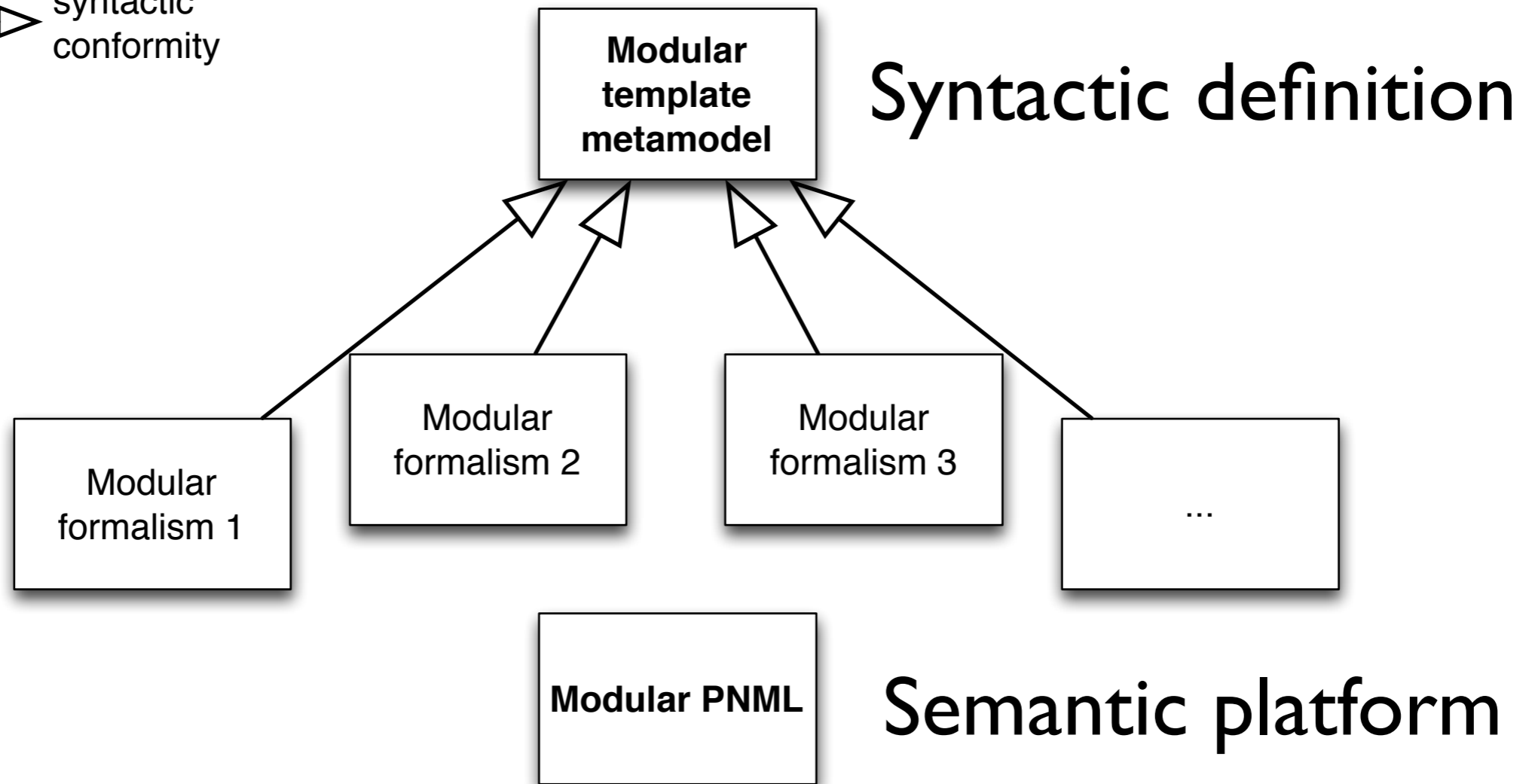

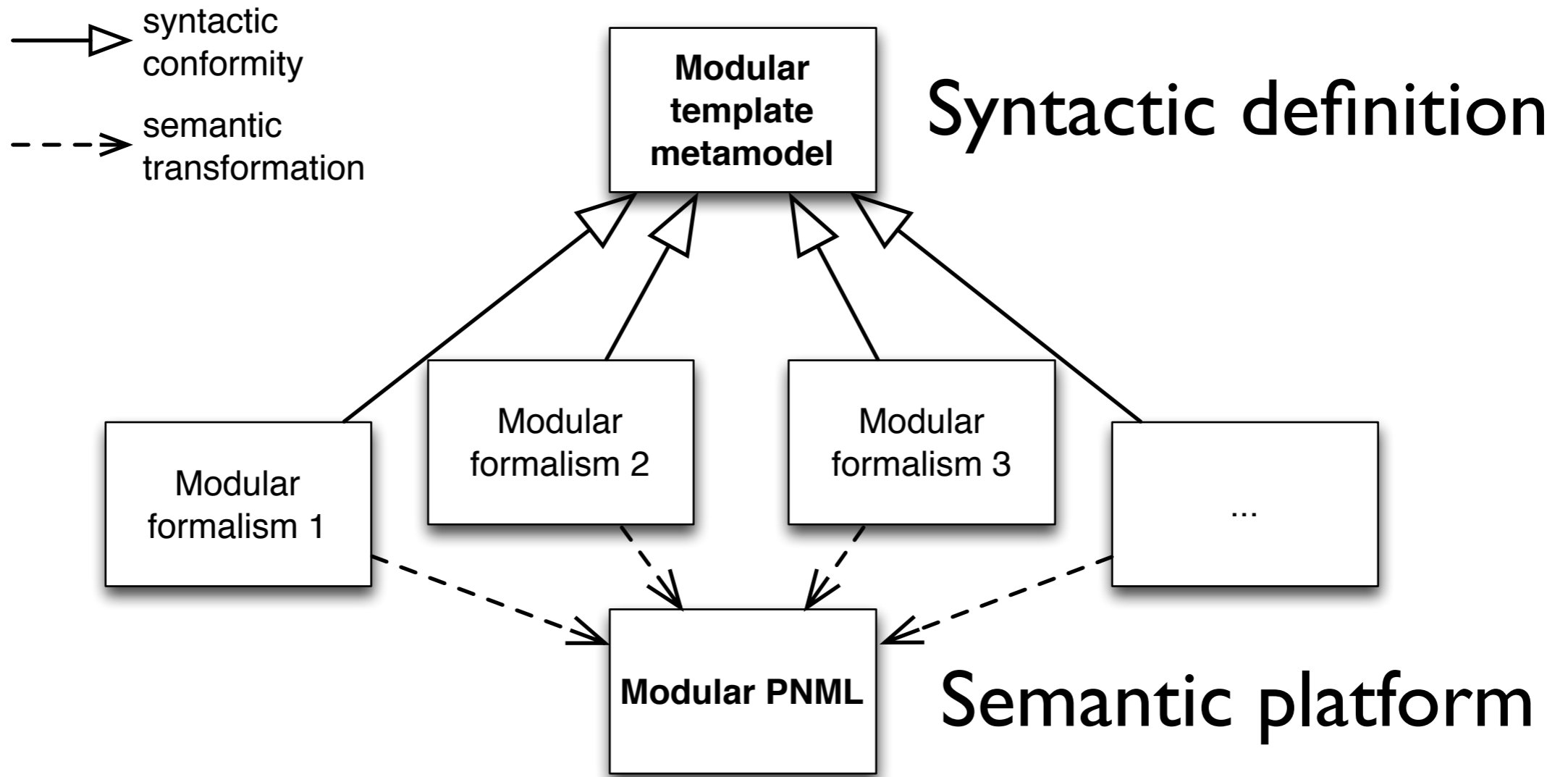

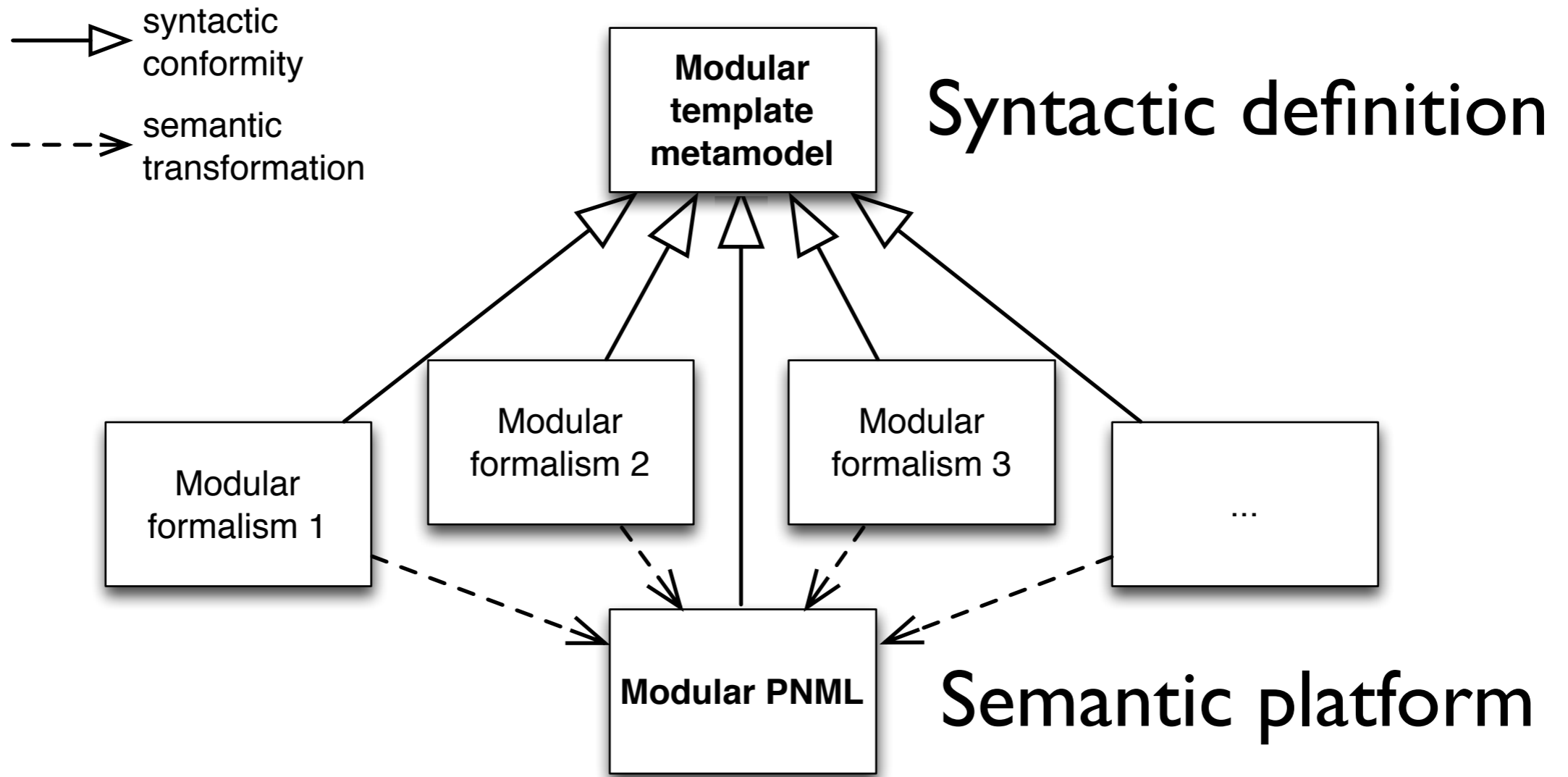

Markup language

Markup language

Unified definition
process

Markup language

**Unified definition
process**

**Inter-formalisms
composition**

Inter-formalisms composition

Inter-formalisms composition

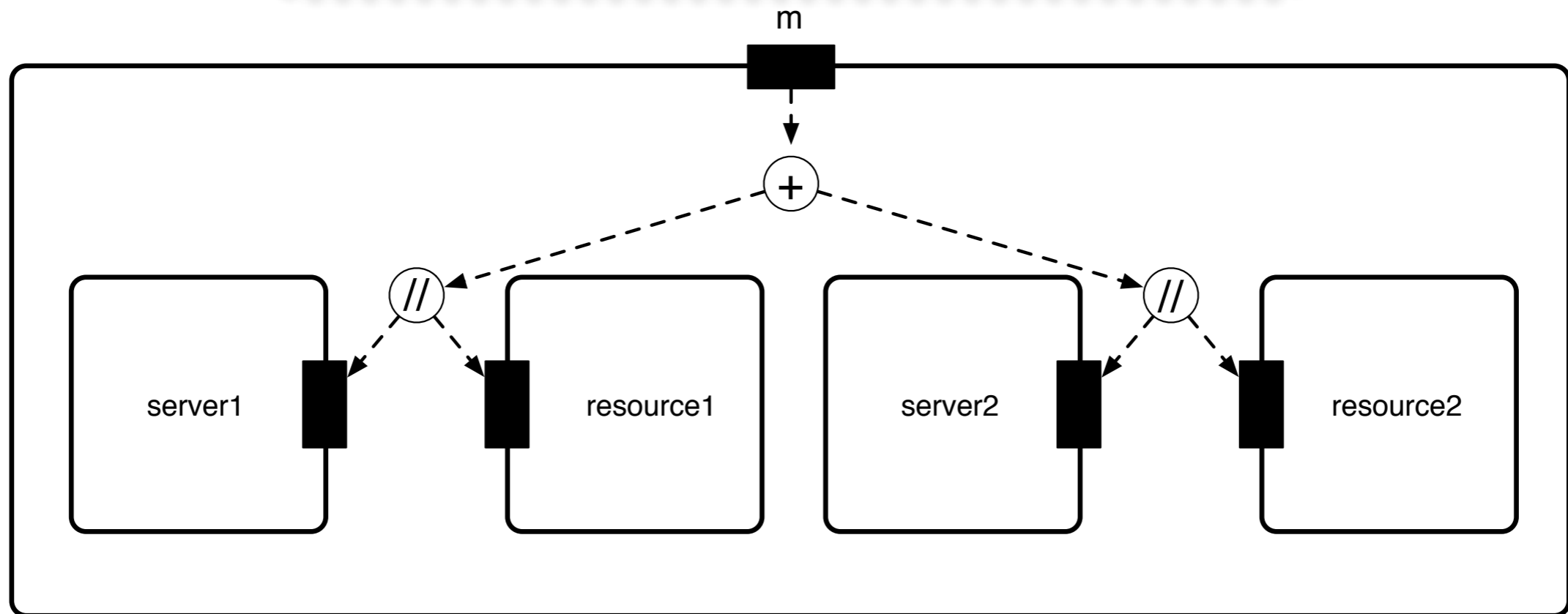
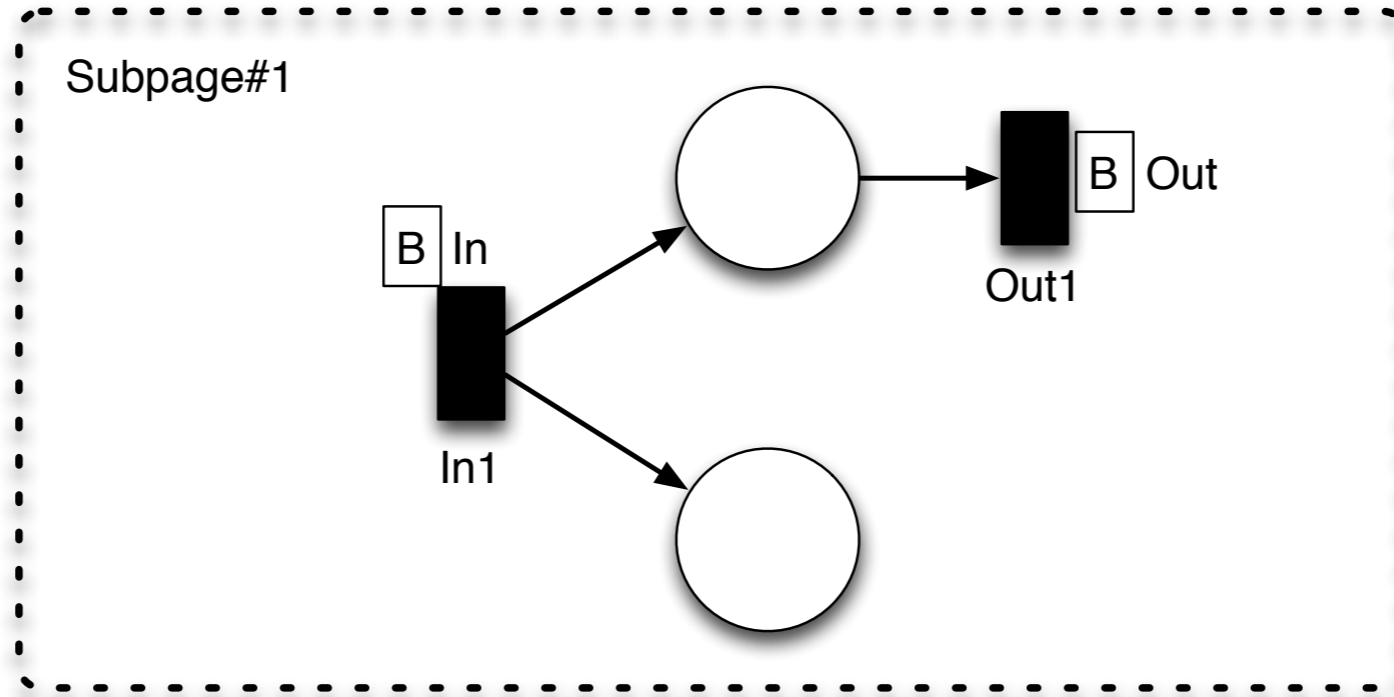

Inter-formalisms composition

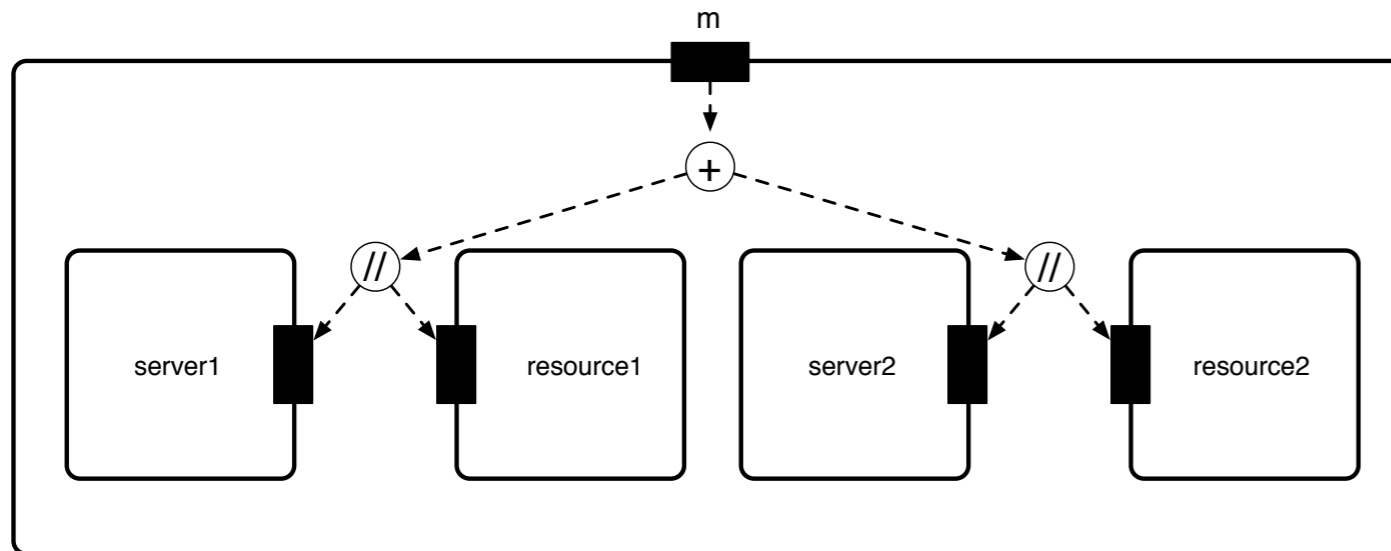
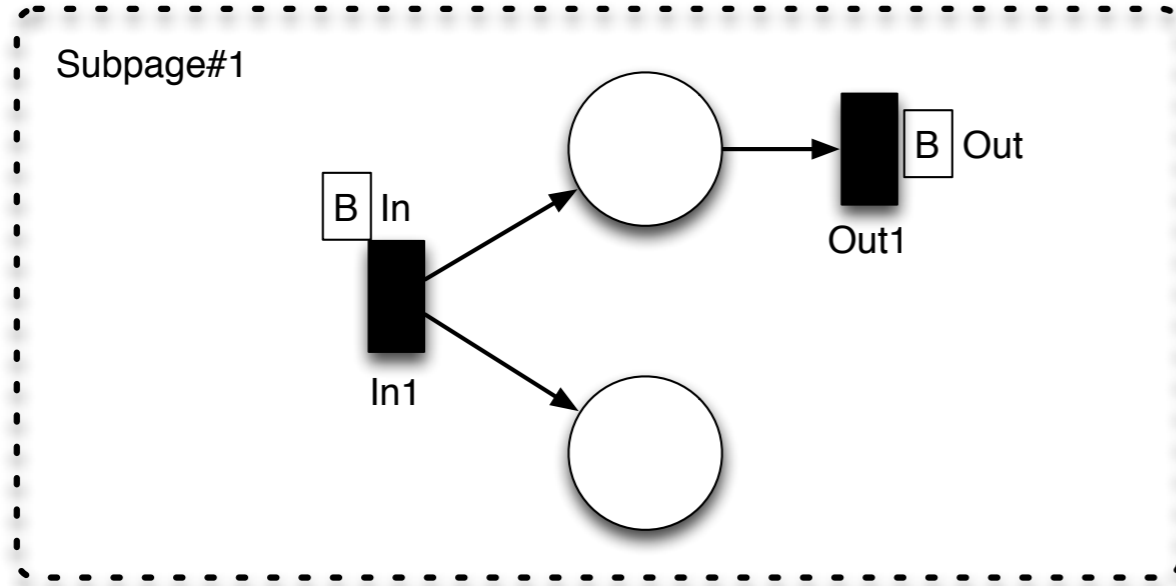

Inter-formalisms composition

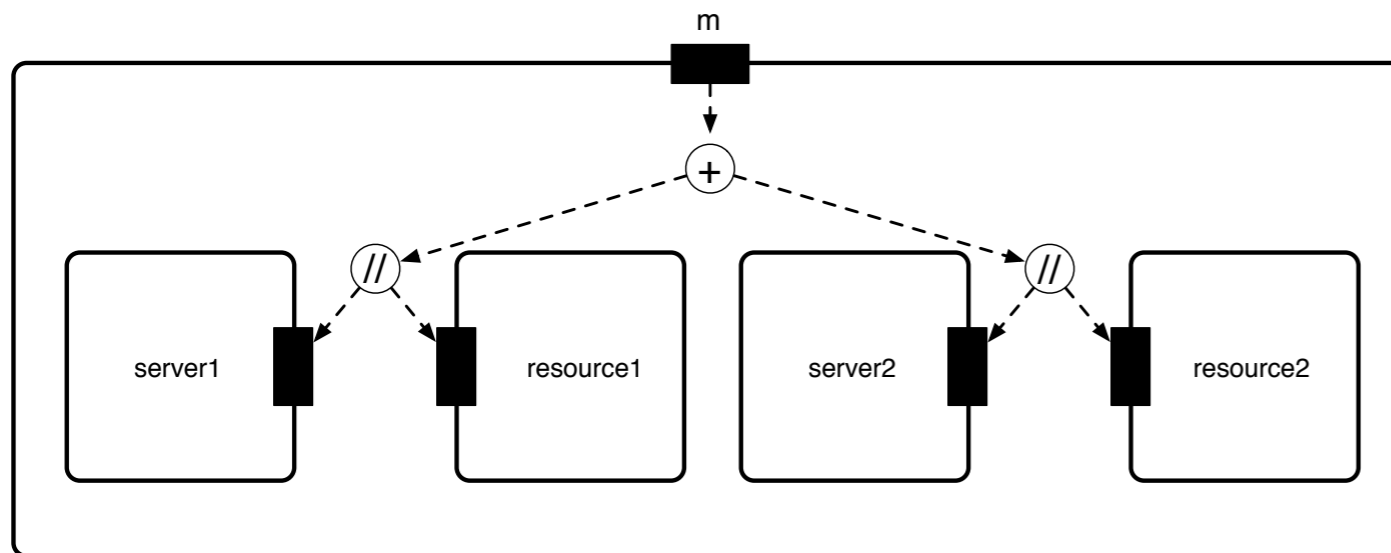
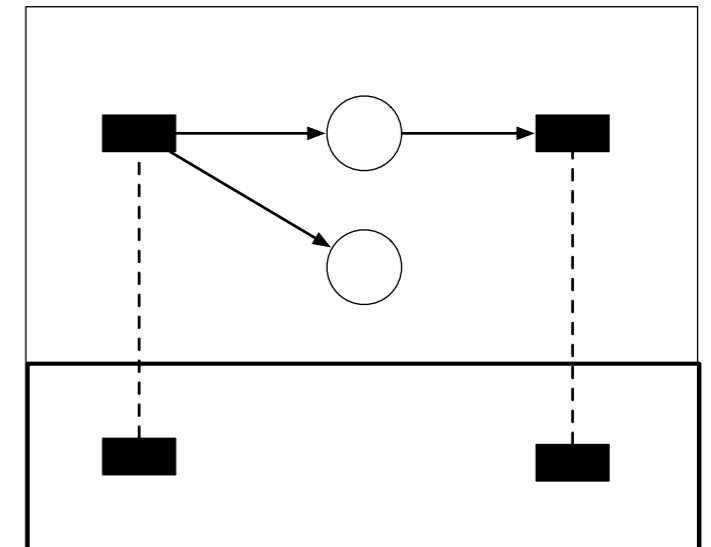
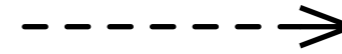
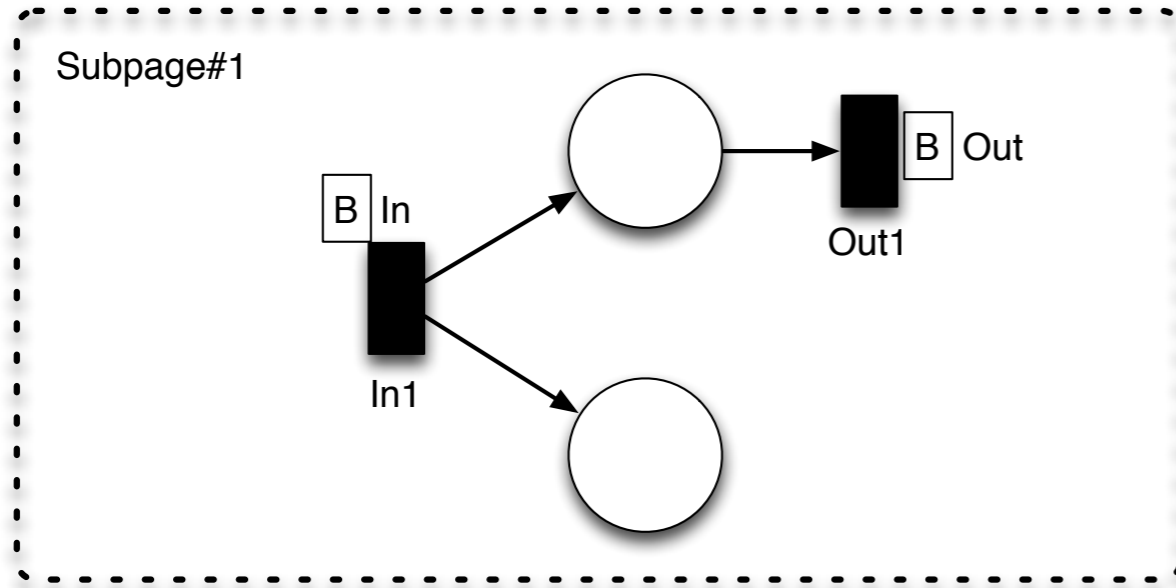

Inter-formalisms composition

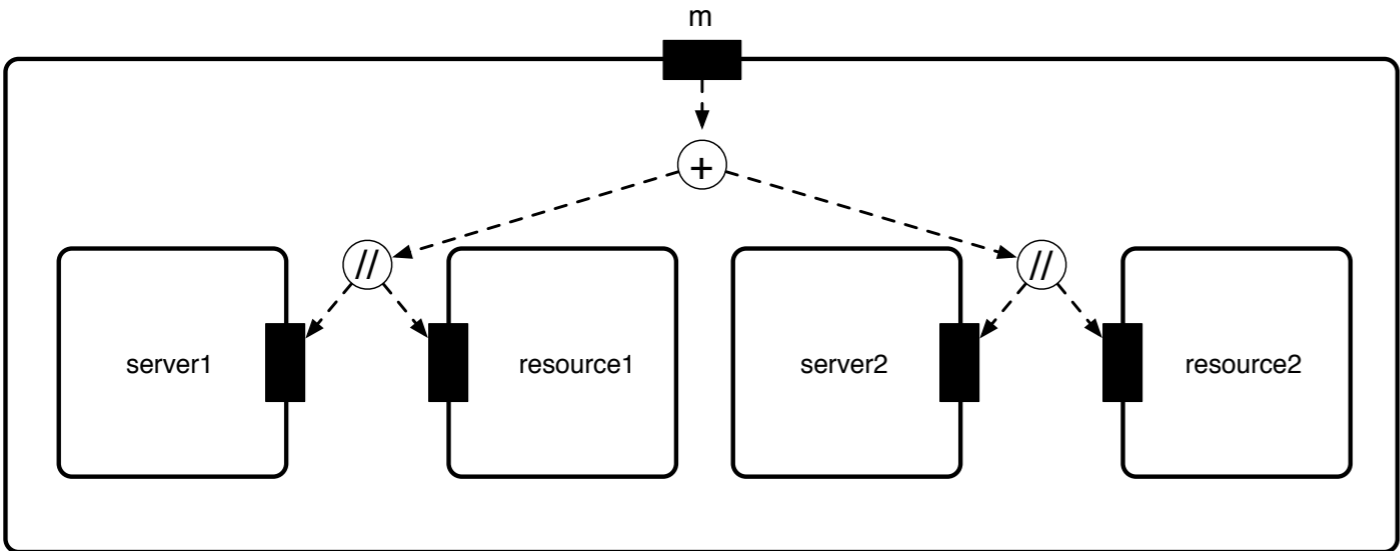
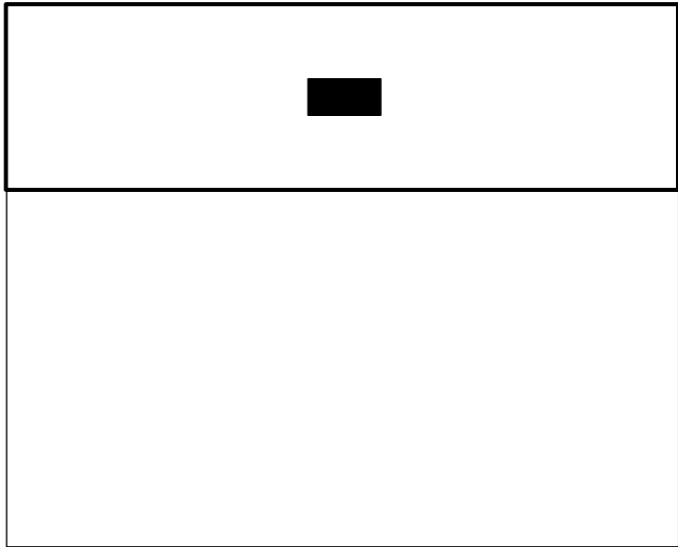
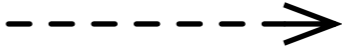
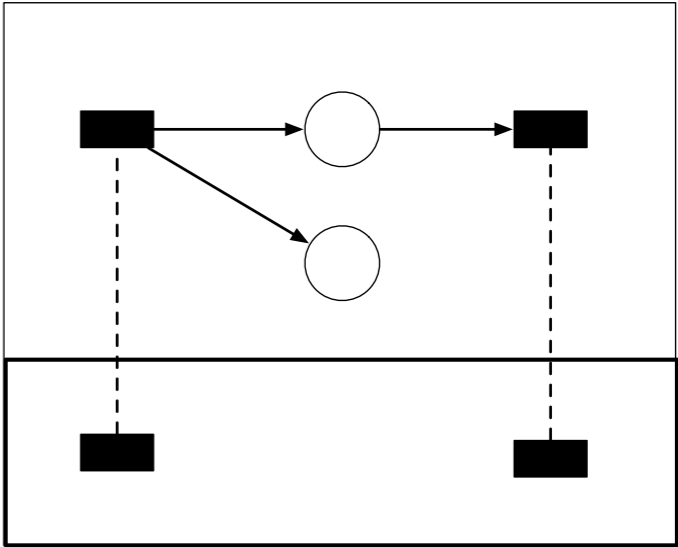
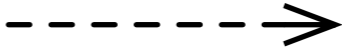
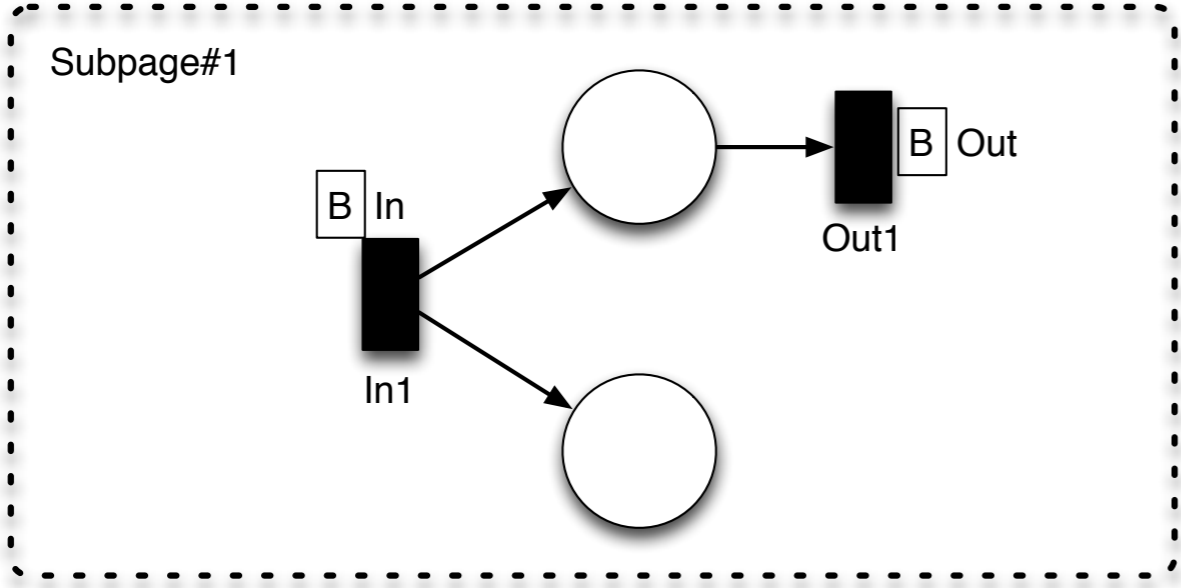

Inter-formalisms composition

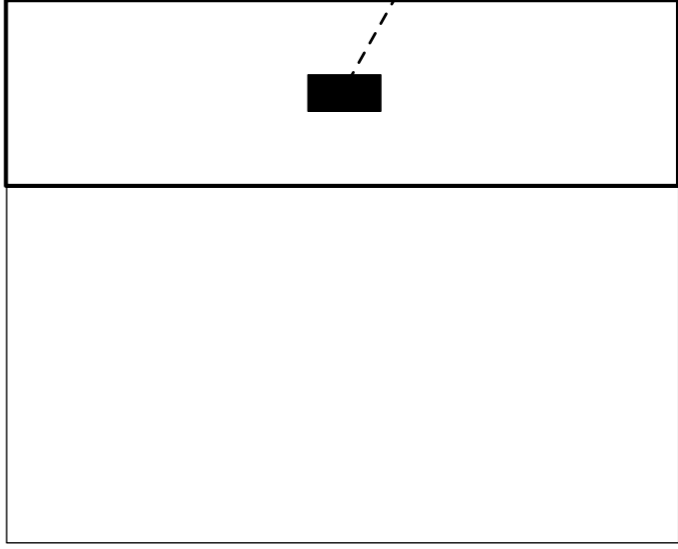
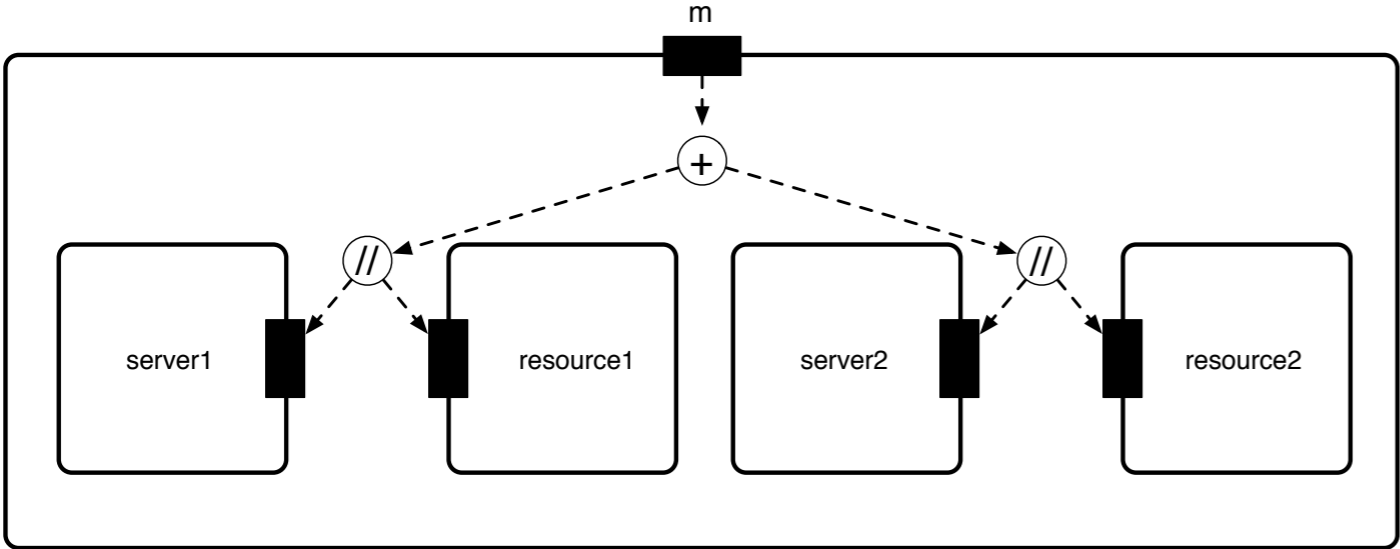
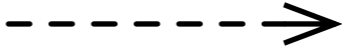
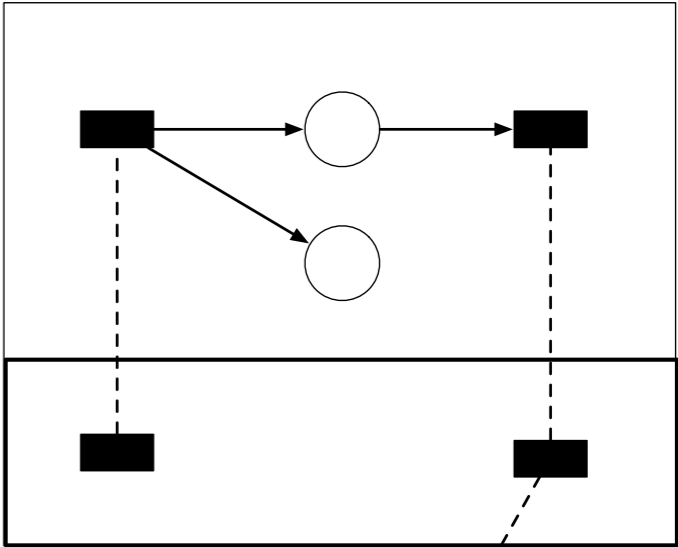
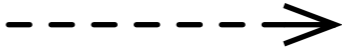
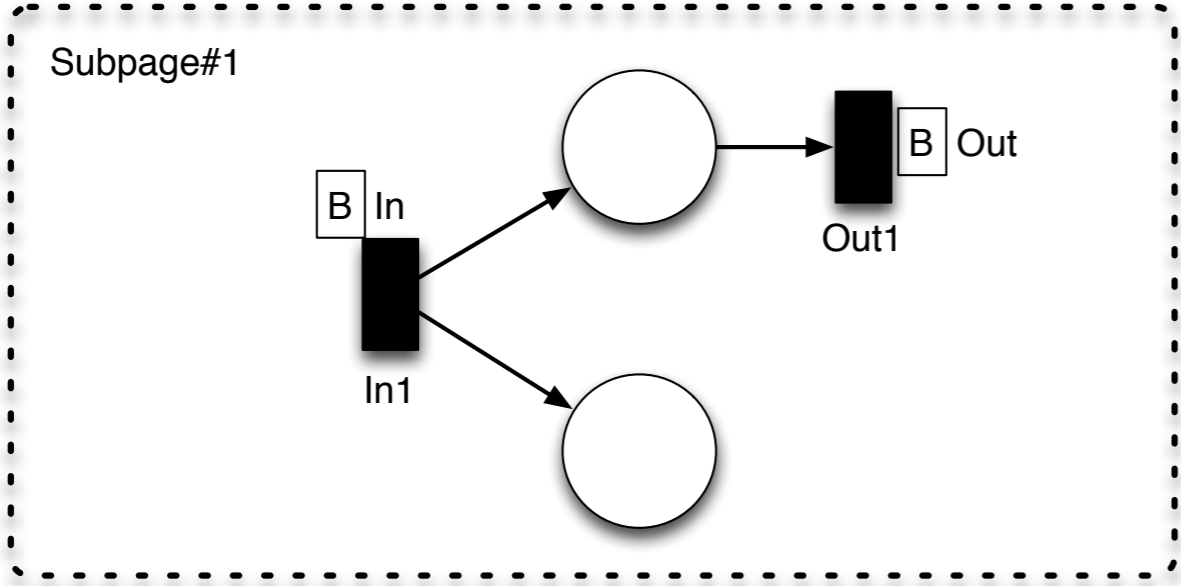

Inter-formalisms composition

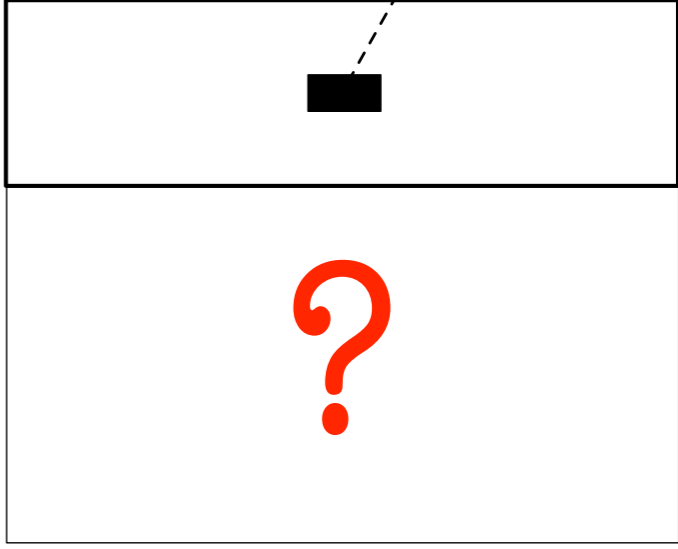
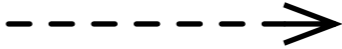
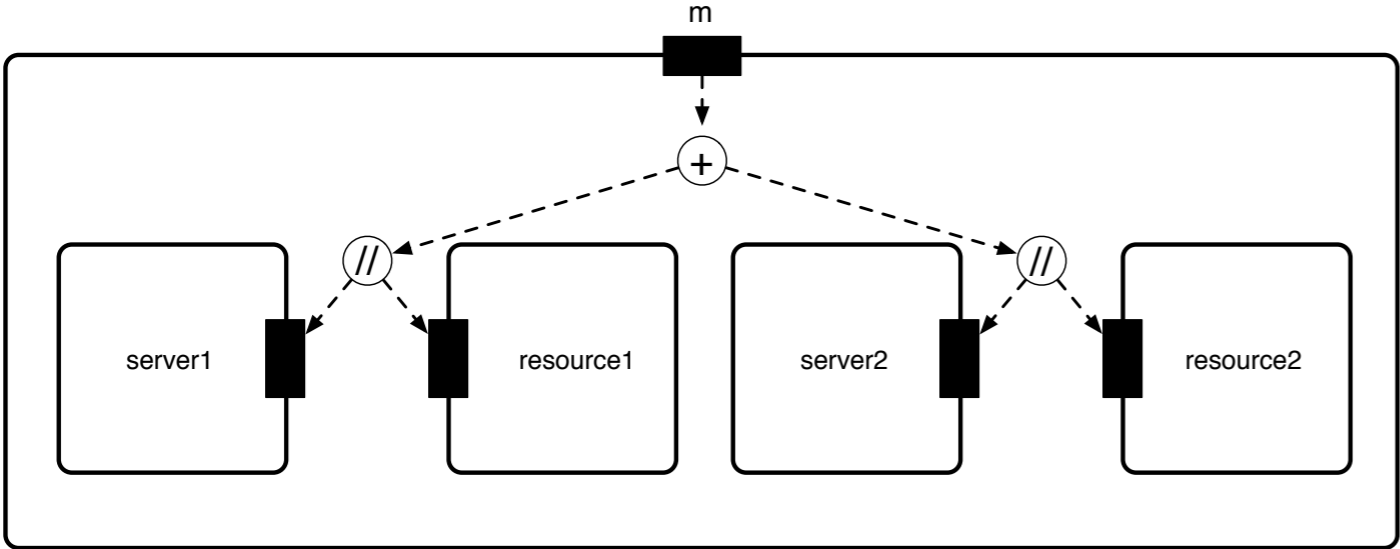
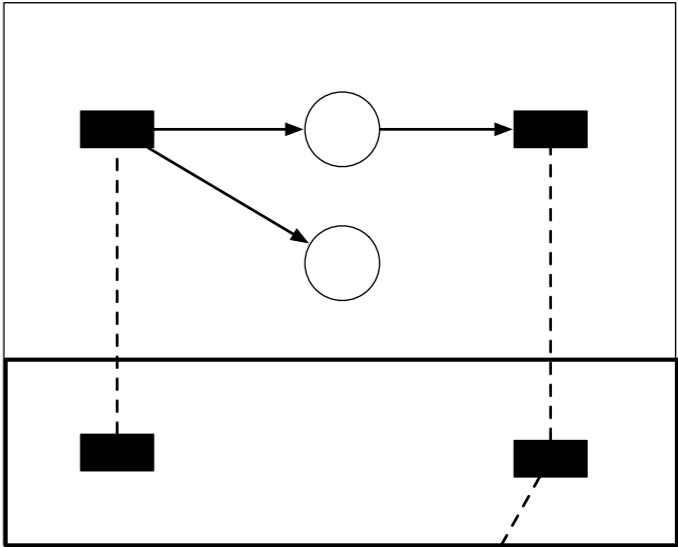
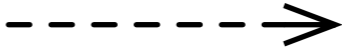
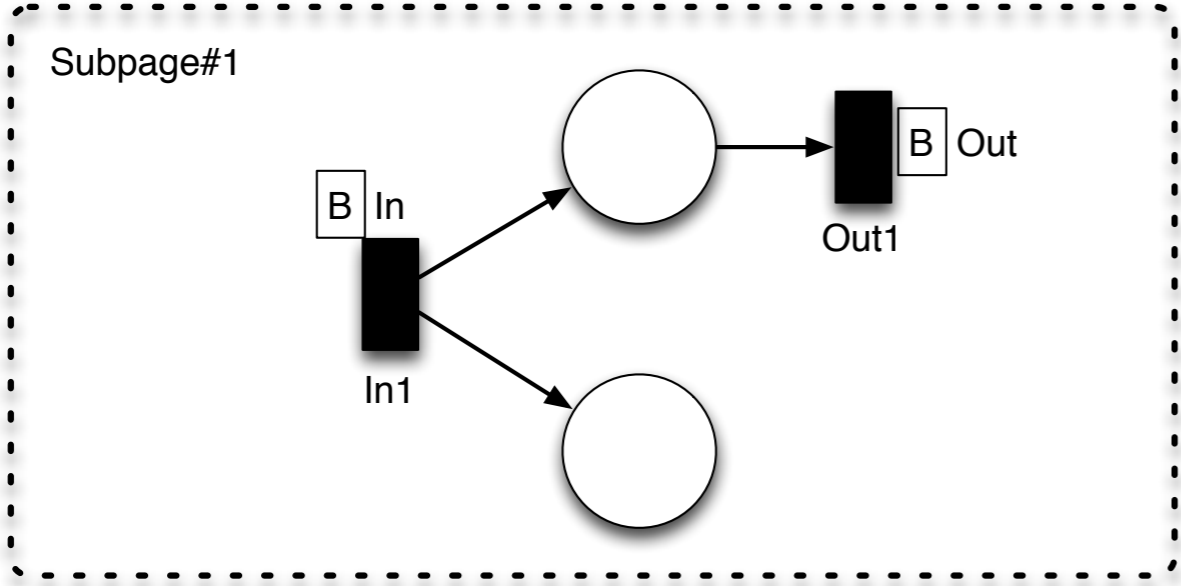

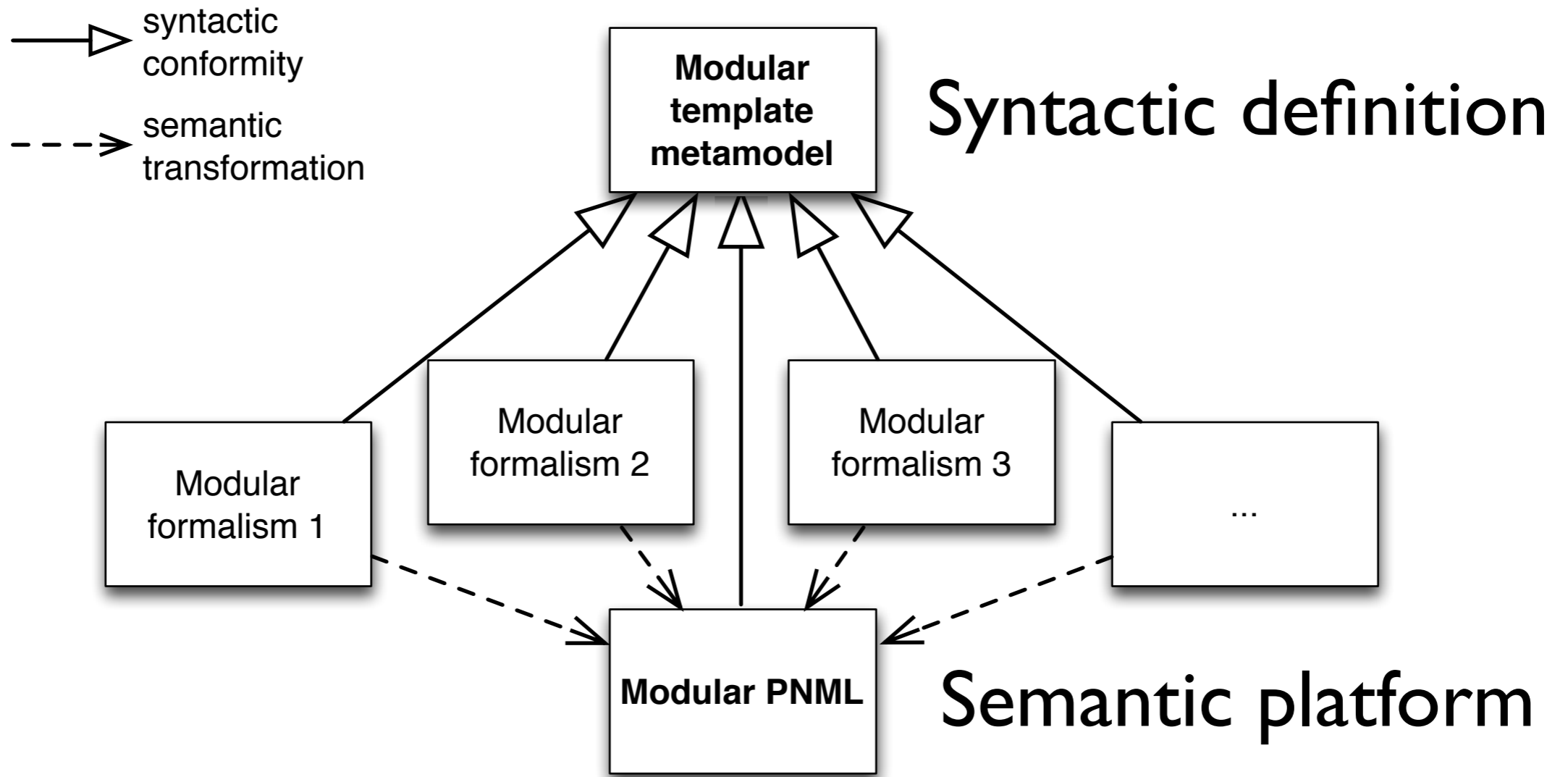

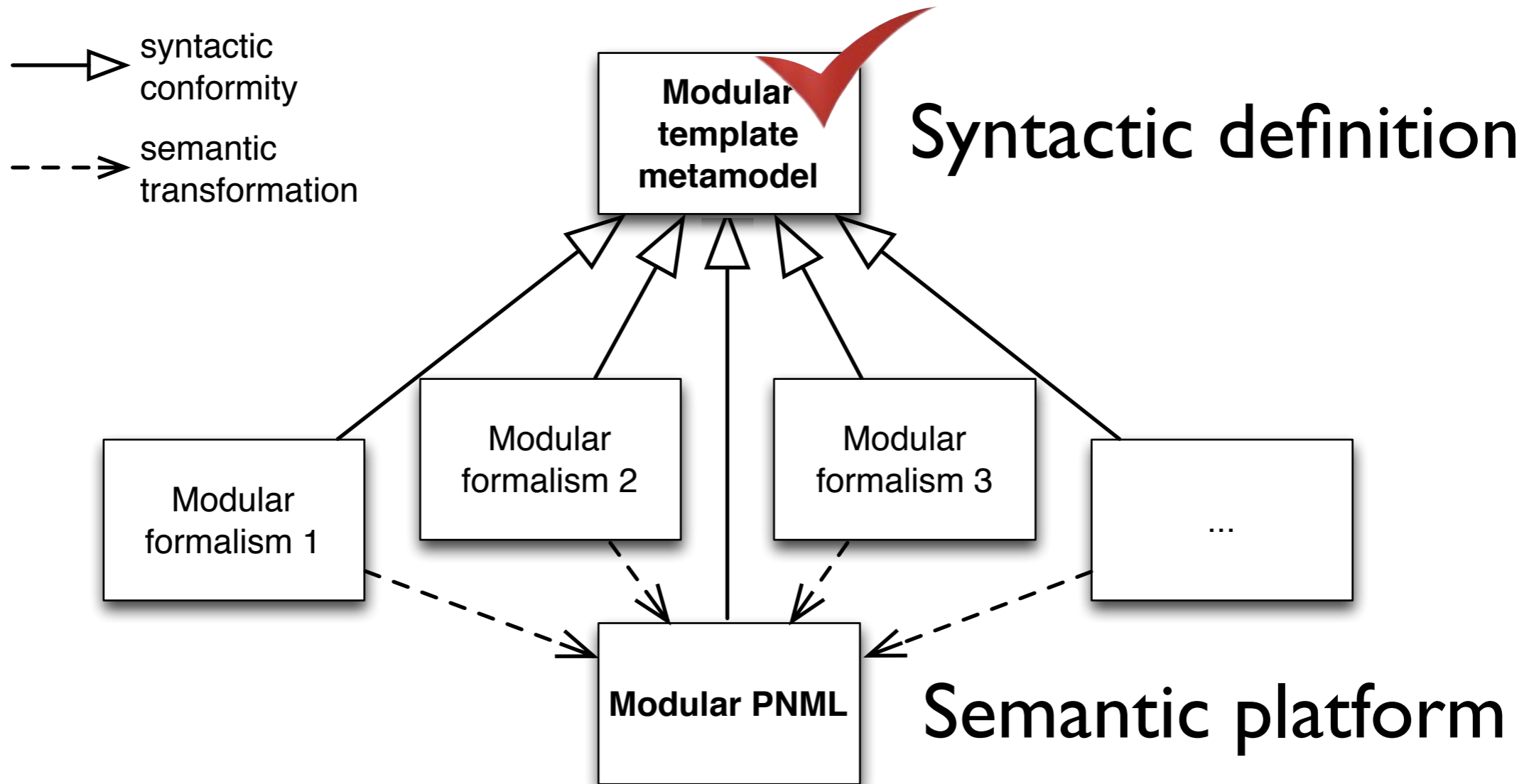

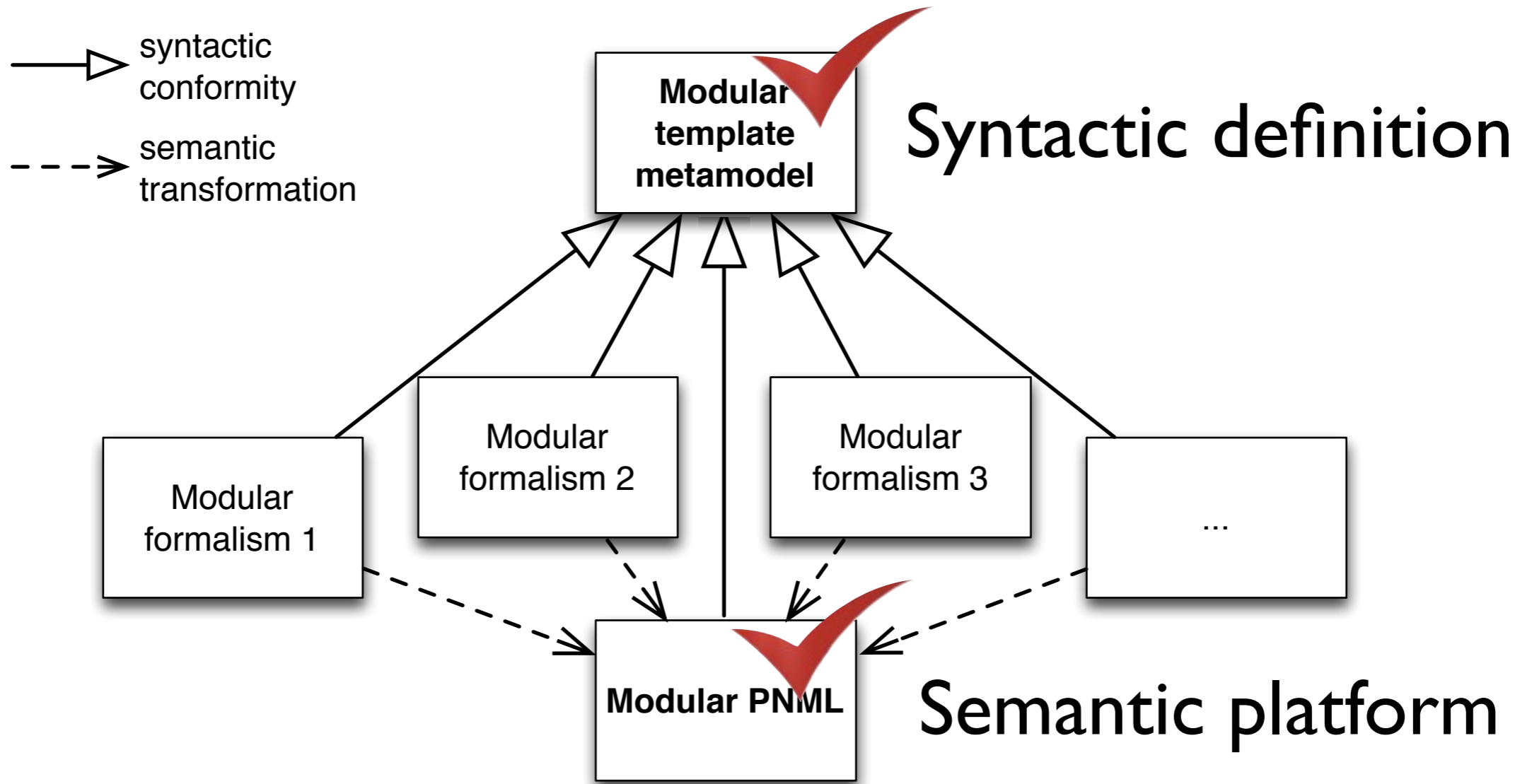

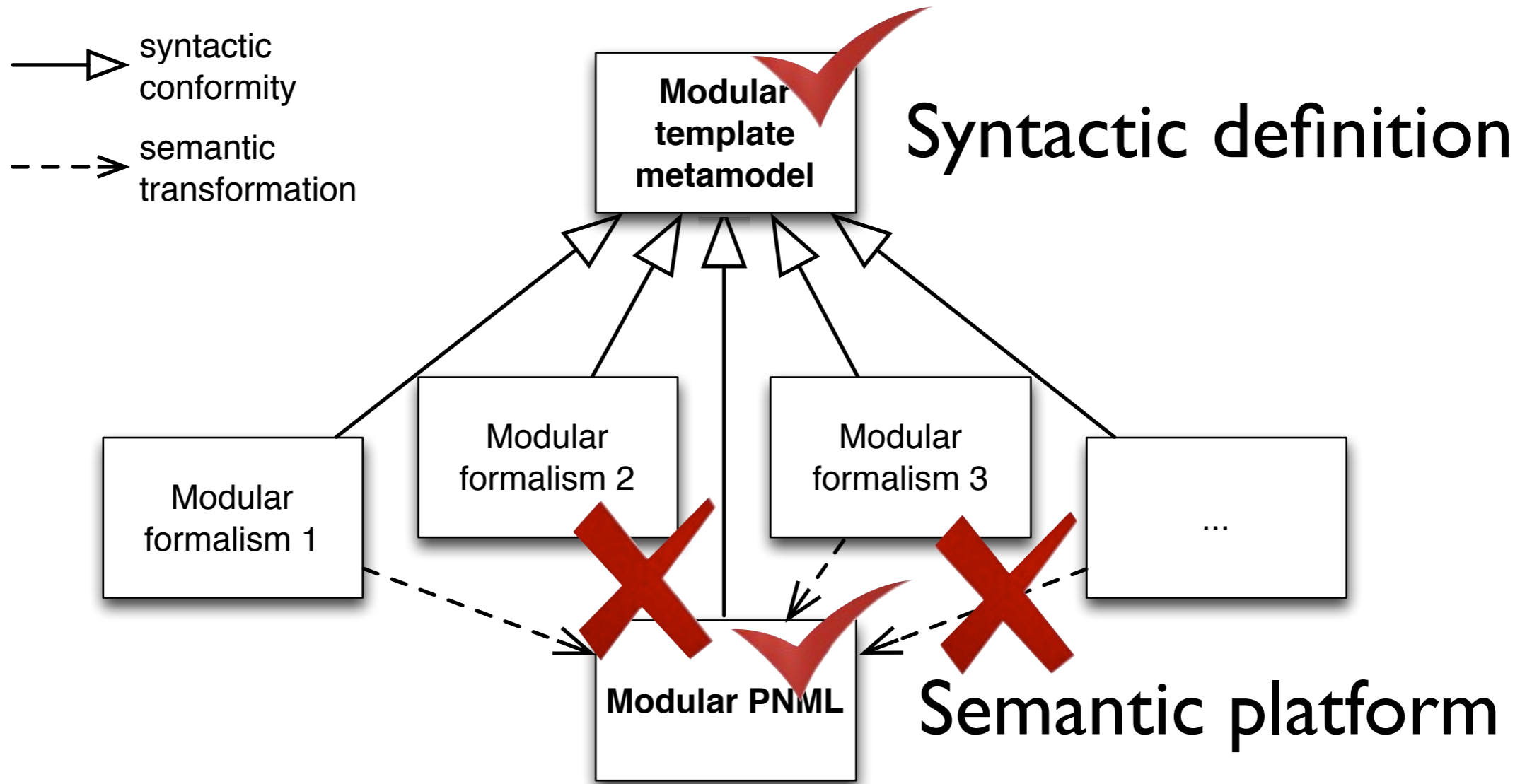

Outline

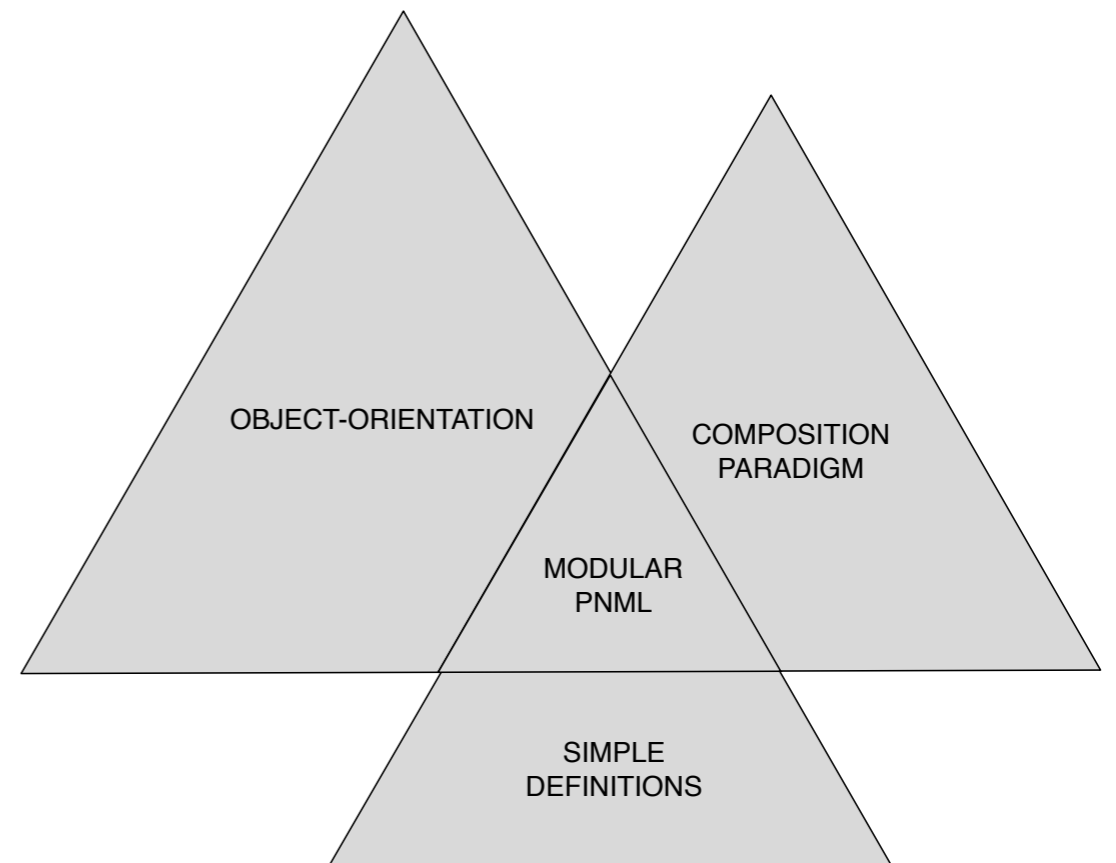
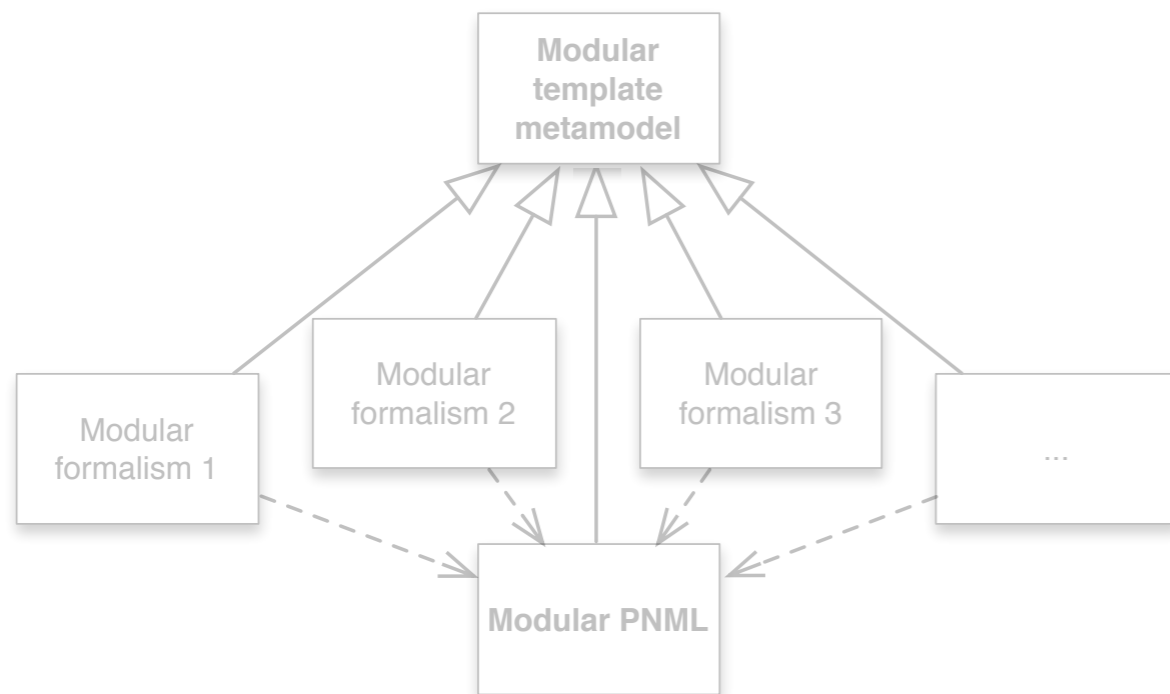
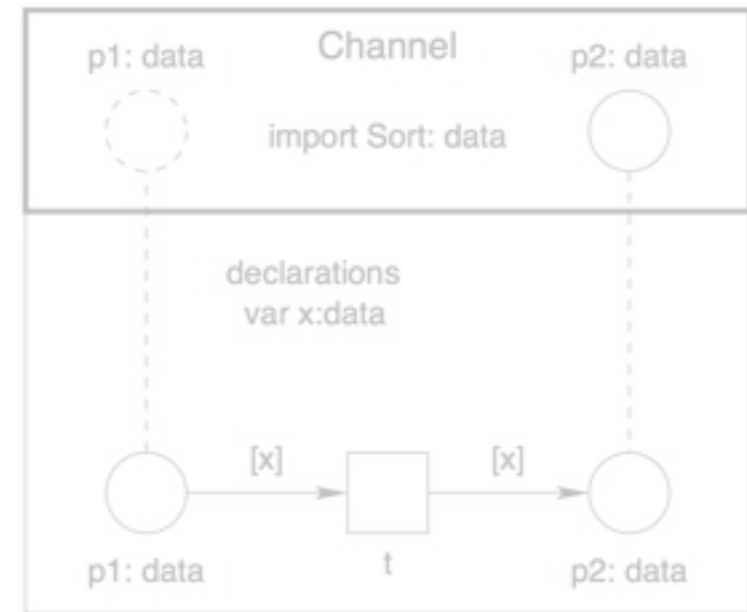

Extensions

Extending Modular PNML

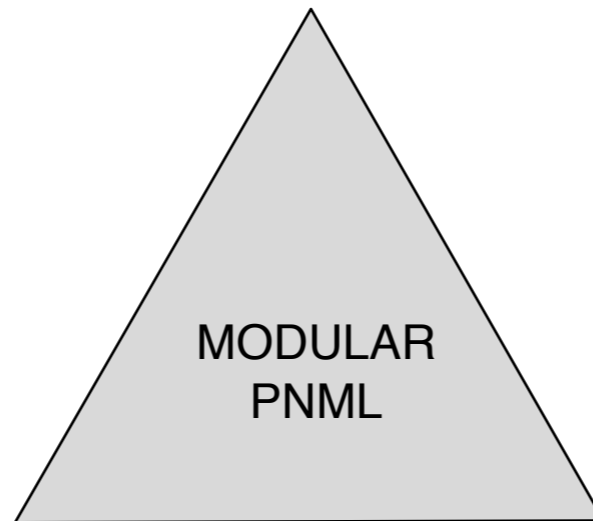

Extending Modular PNML

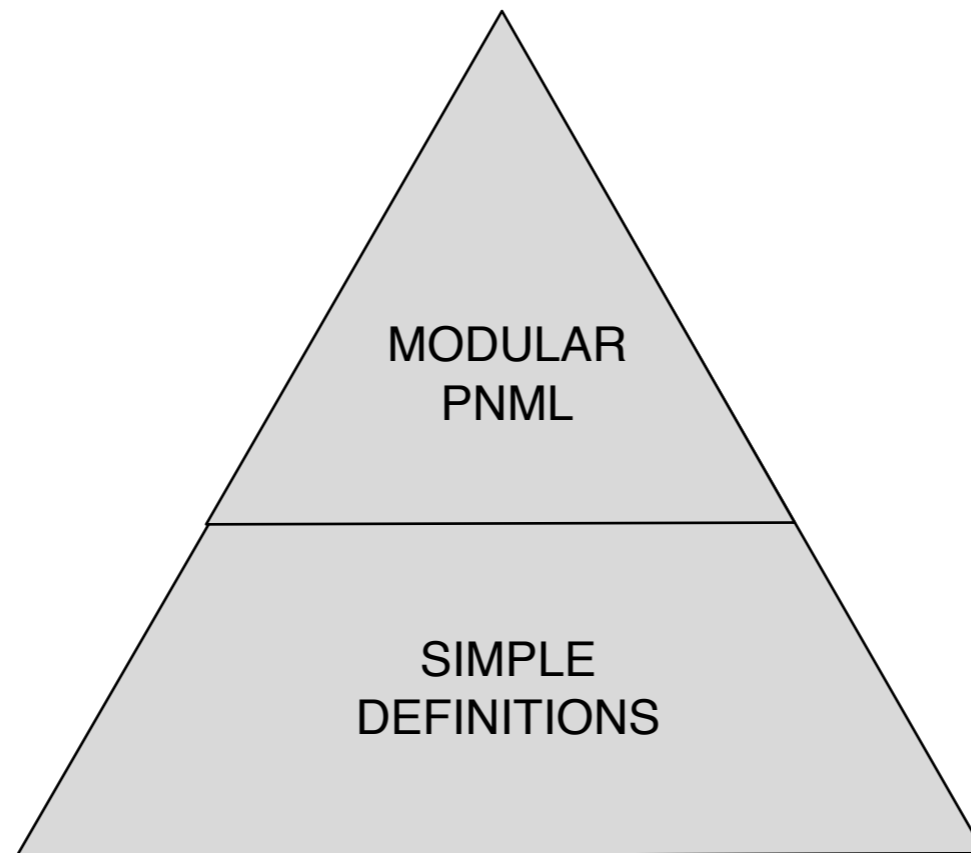

Extending Modular PNML

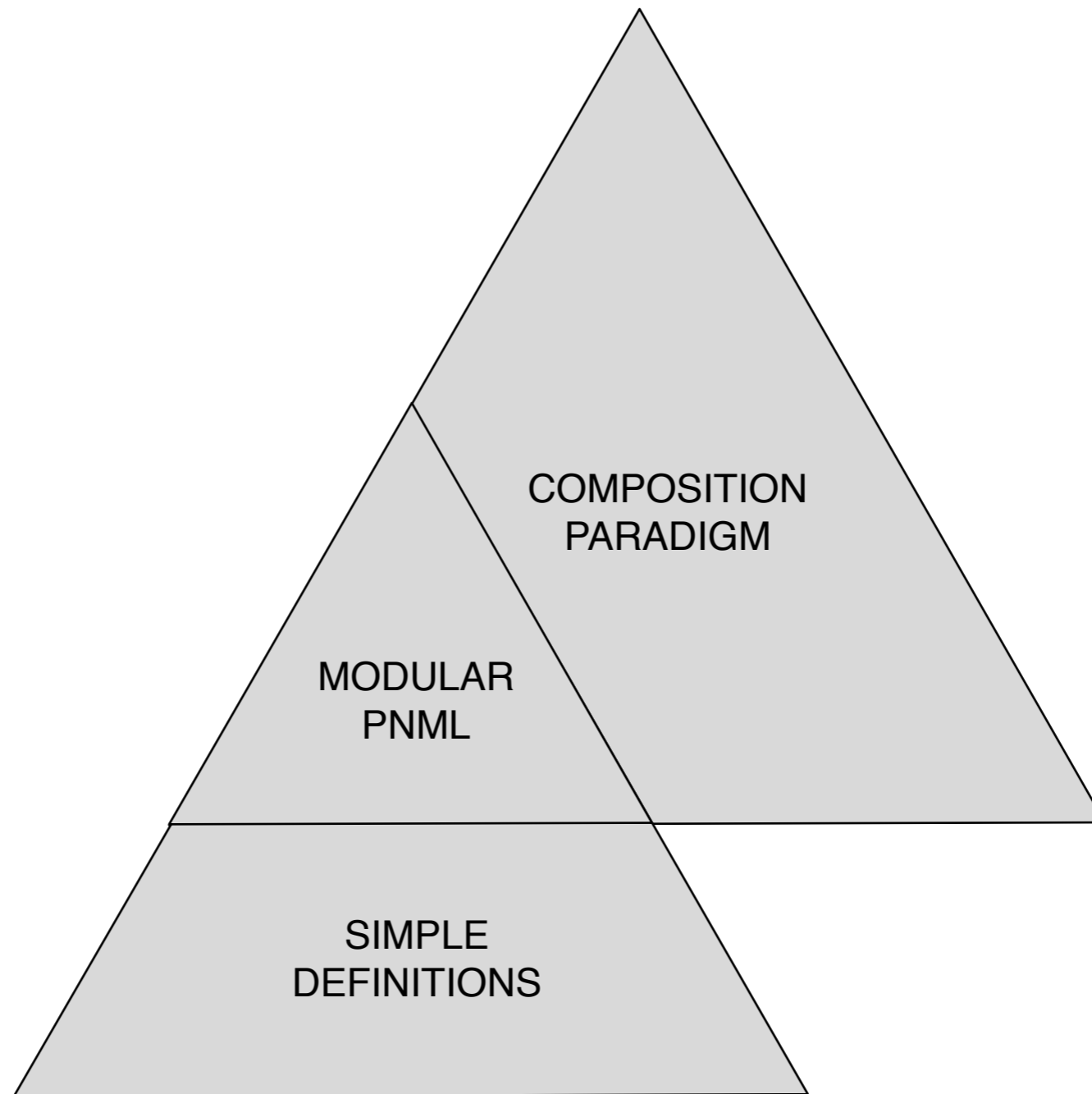

Extending Modular PNML

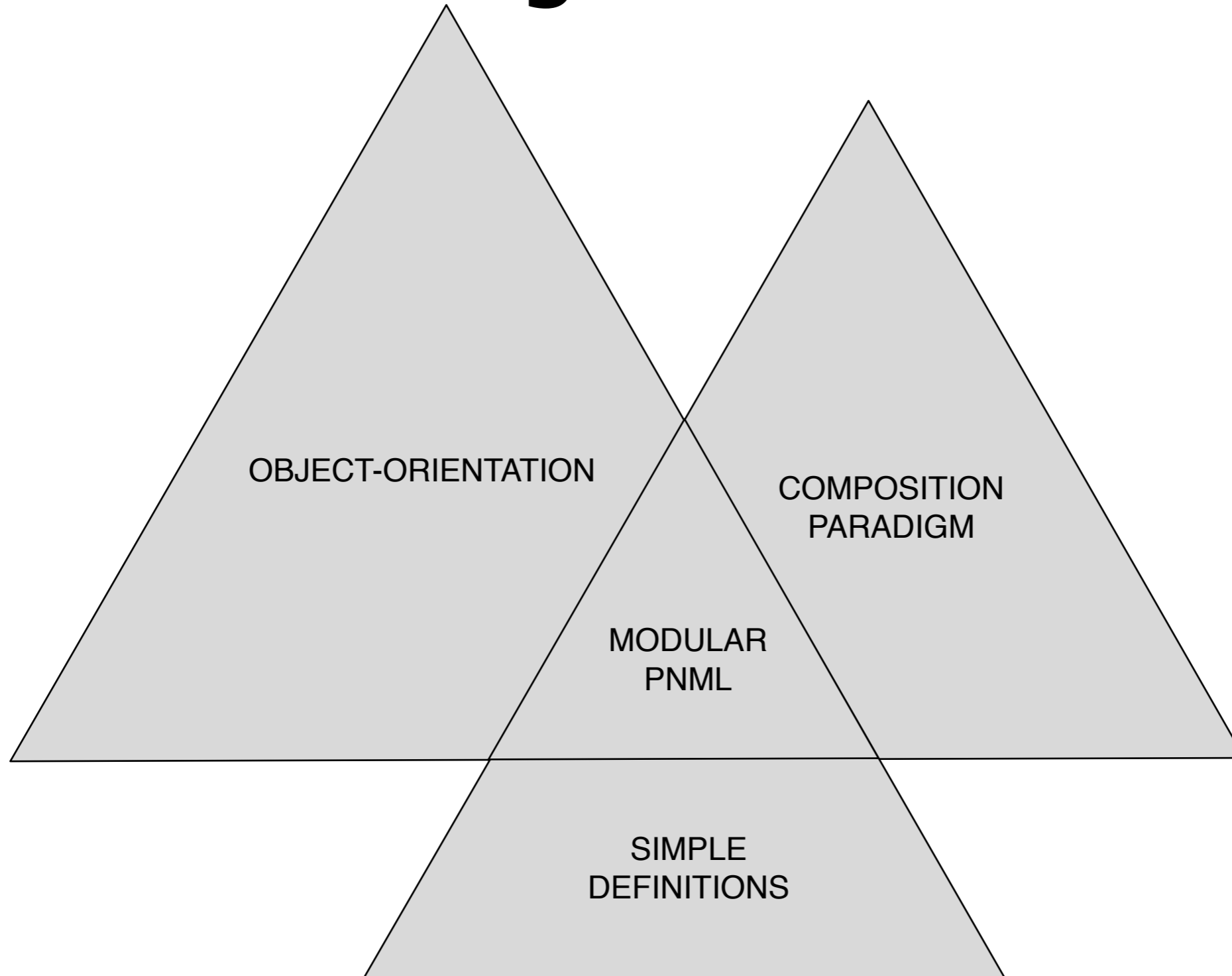

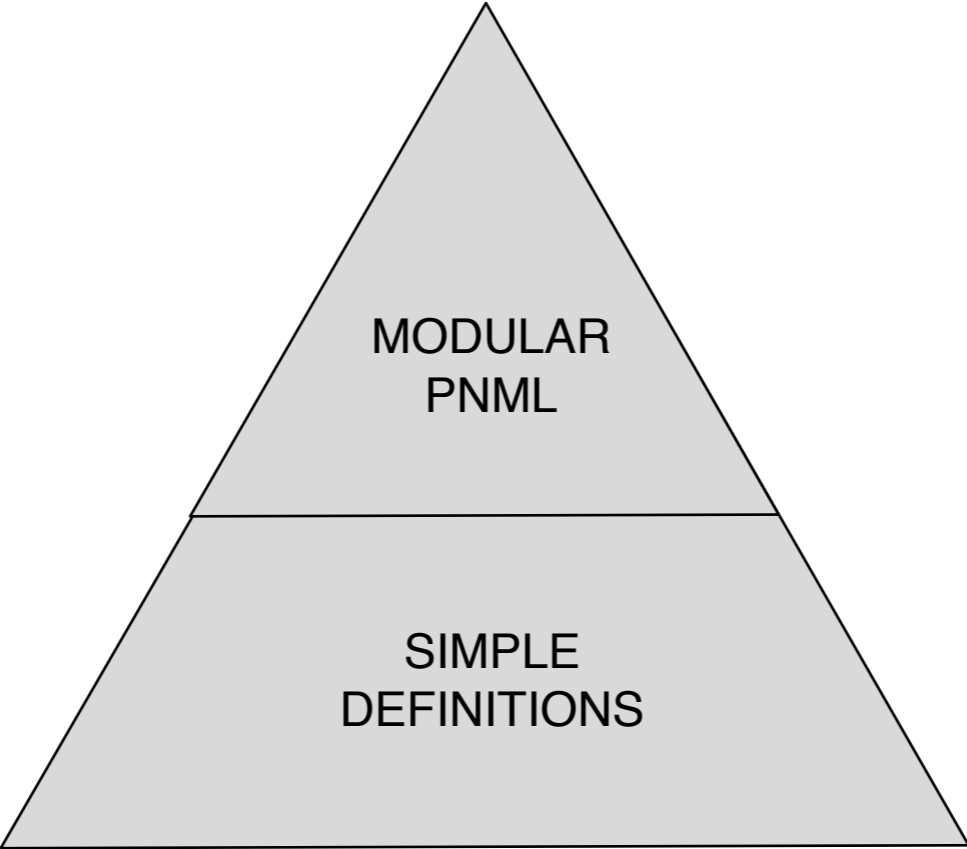

Enrich the current definitions

Enrich the current definitions

Parameterized interface transitions

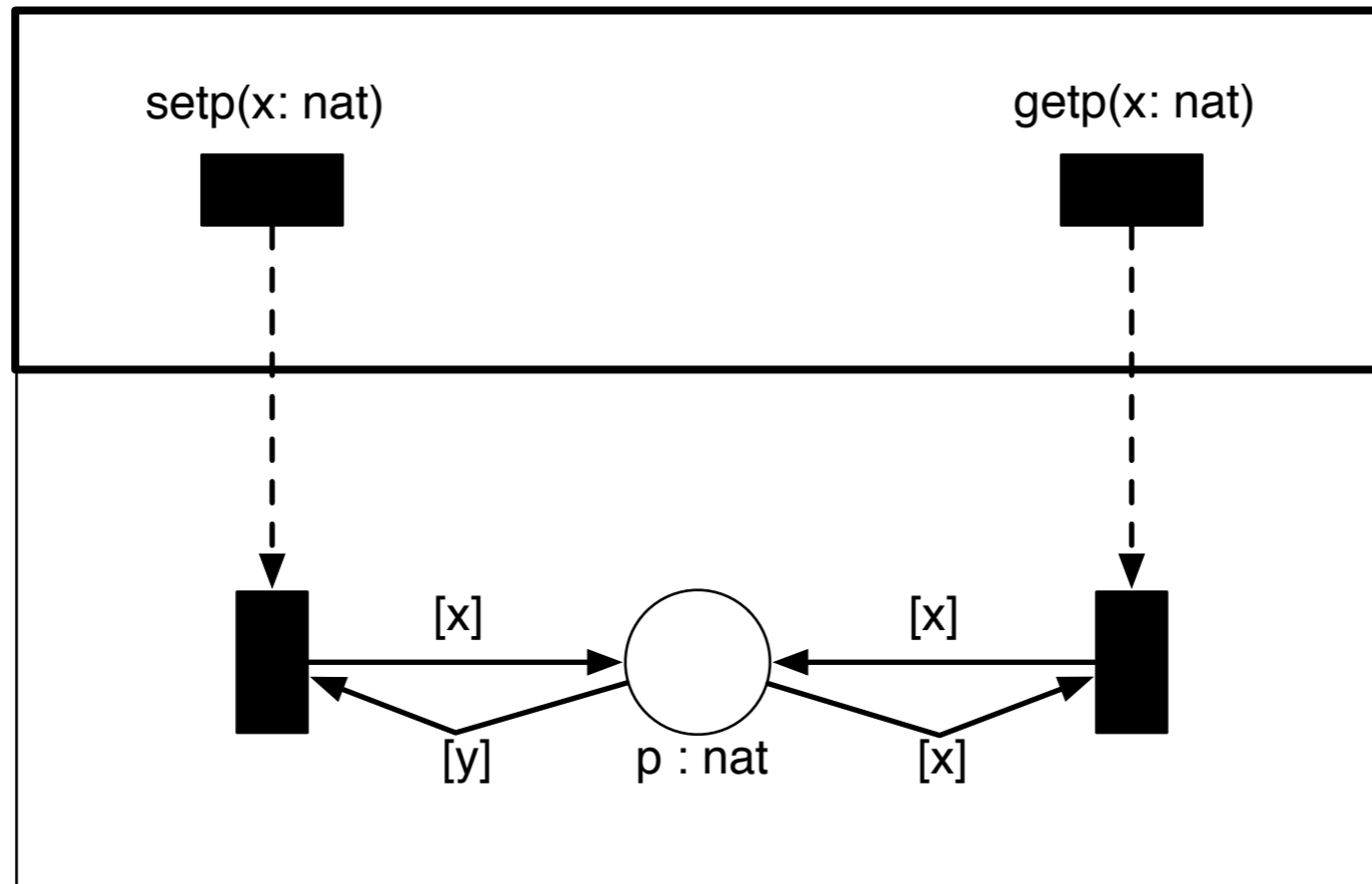

Enrich the current definitions

Parameterized interface elements

Enrich the current definitions

Parameterized interface elements

Duplication of service calls

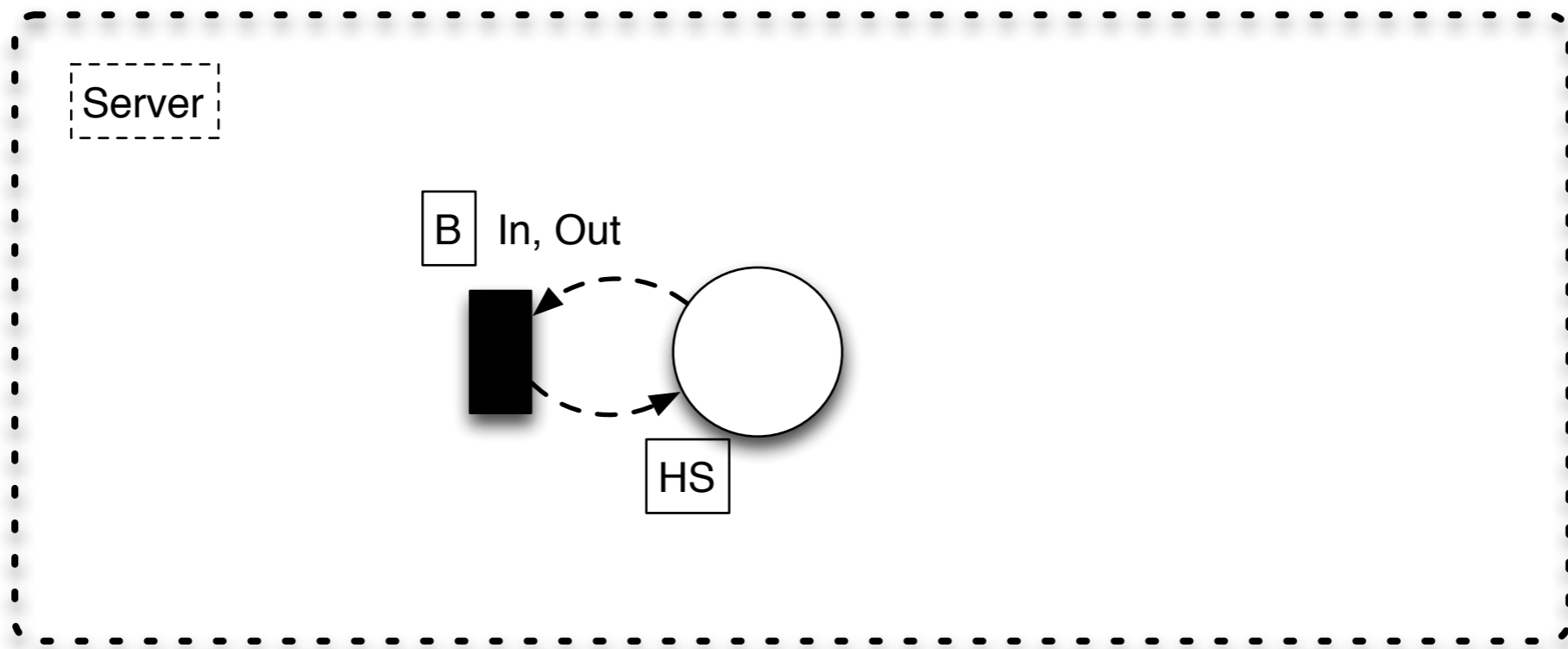
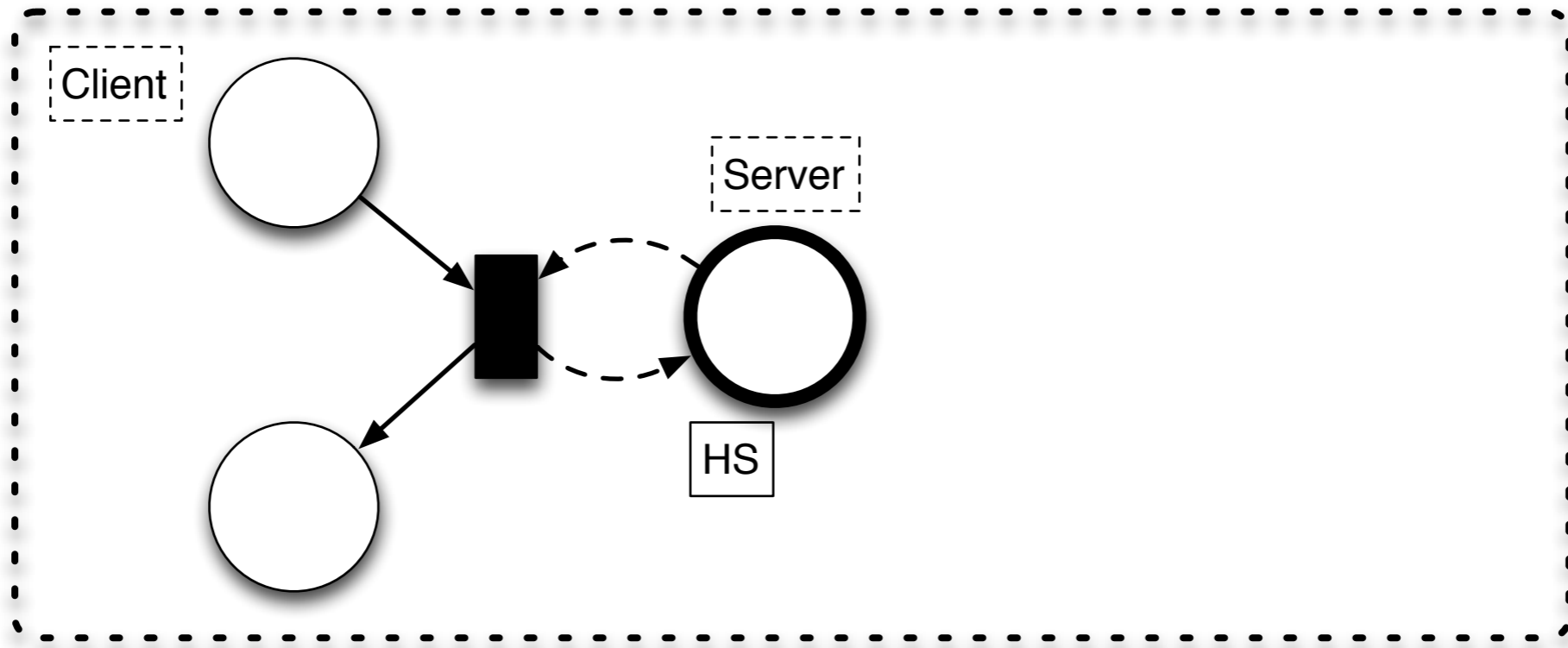

Hubert, Jensen, Shapiro, 1991
Hierarchies in Coloured Petri Nets

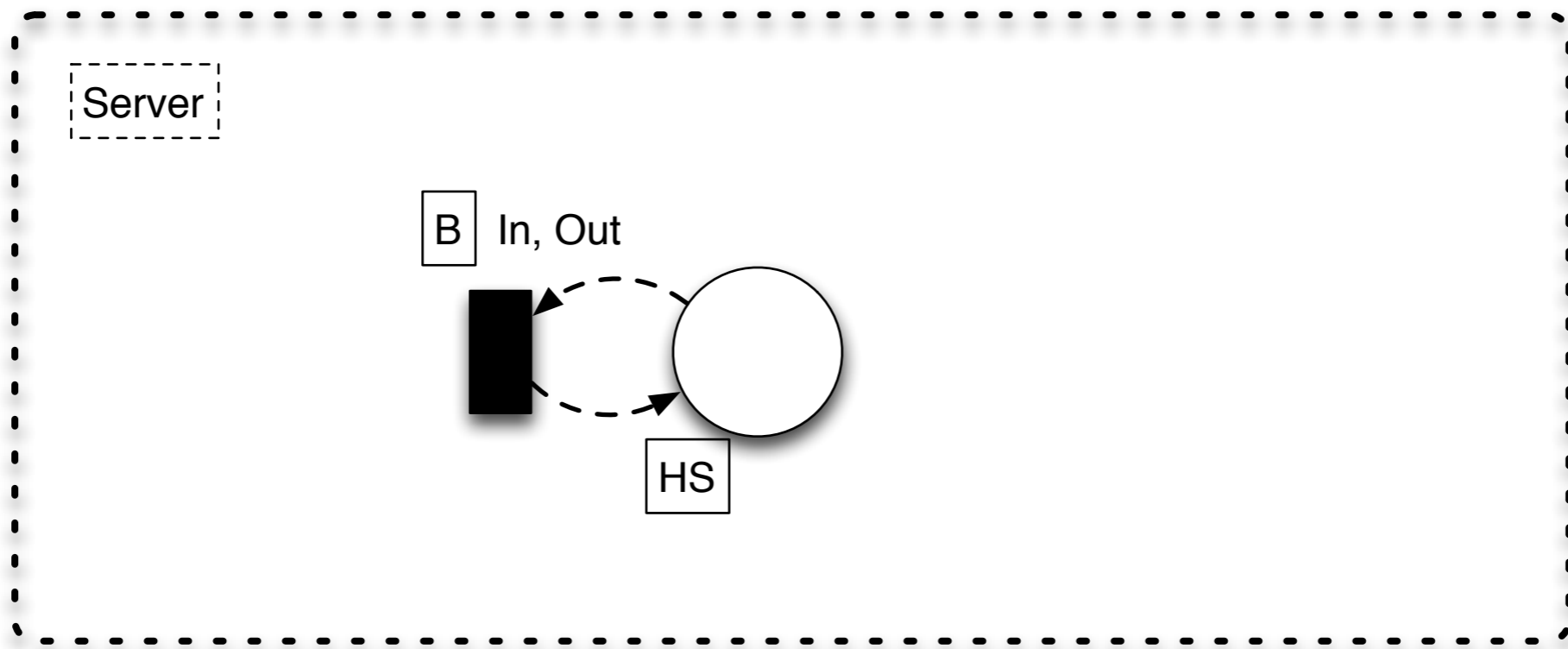
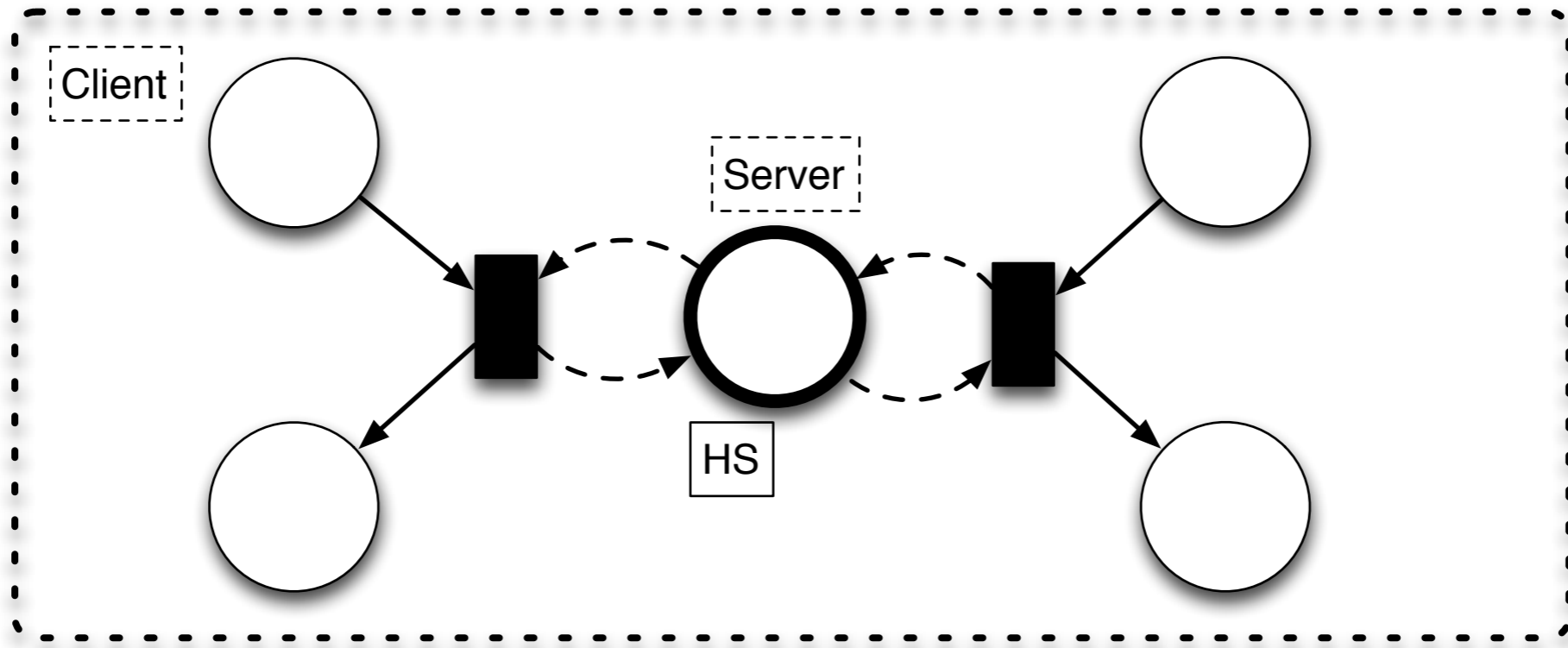

Hubert, Jensen, Shapiro, 1991
Hierarchies in Coloured Petri Nets

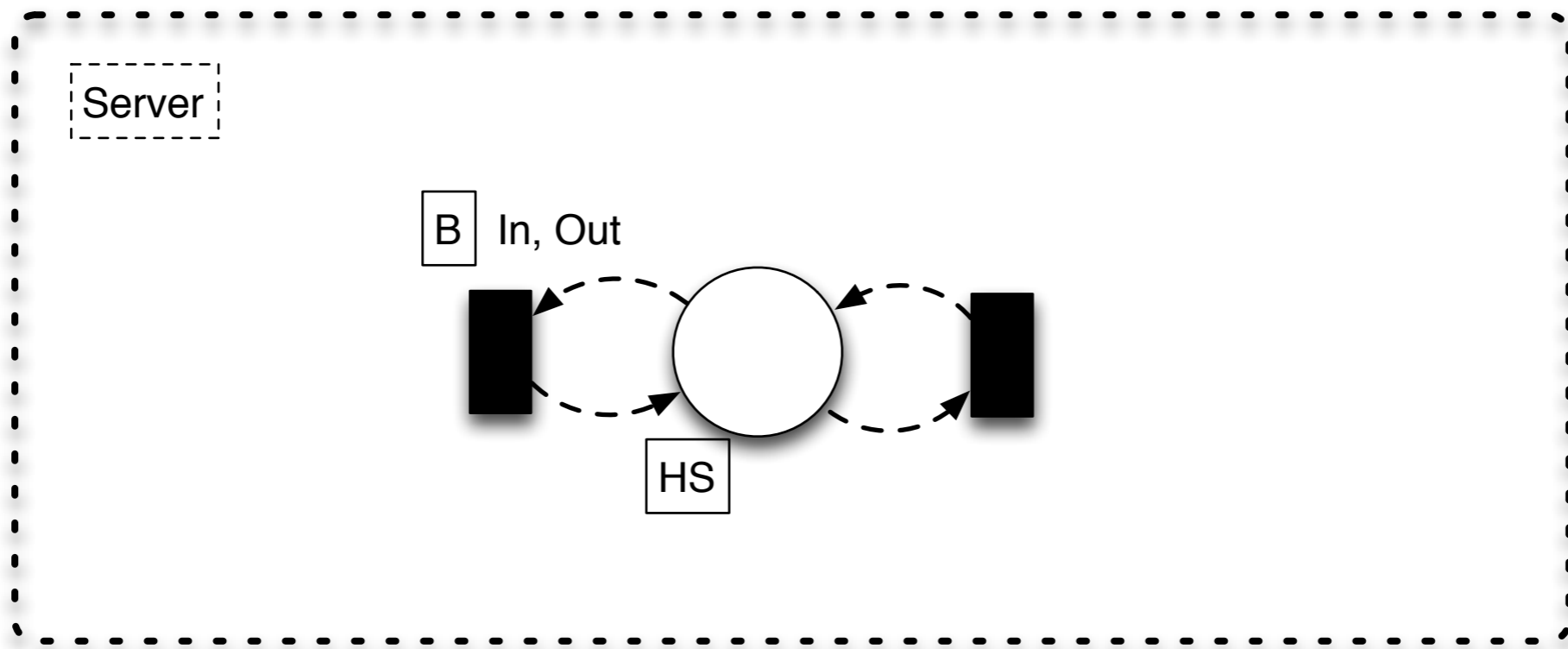
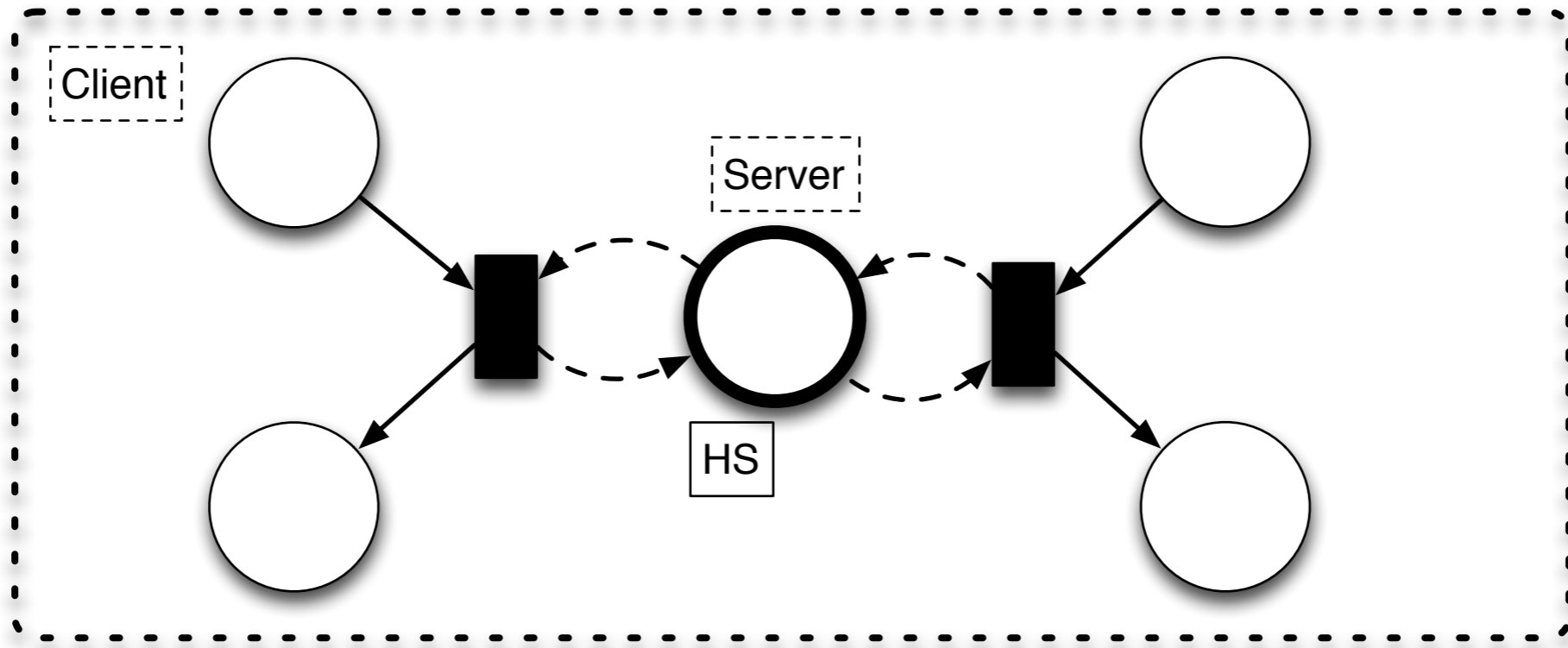

Hubert, Jensen, Shapiro, 1991
Hierarchies in Coloured Petri Nets

Enrich the current definitions

Parameterized interface elements

Duplication of service calls

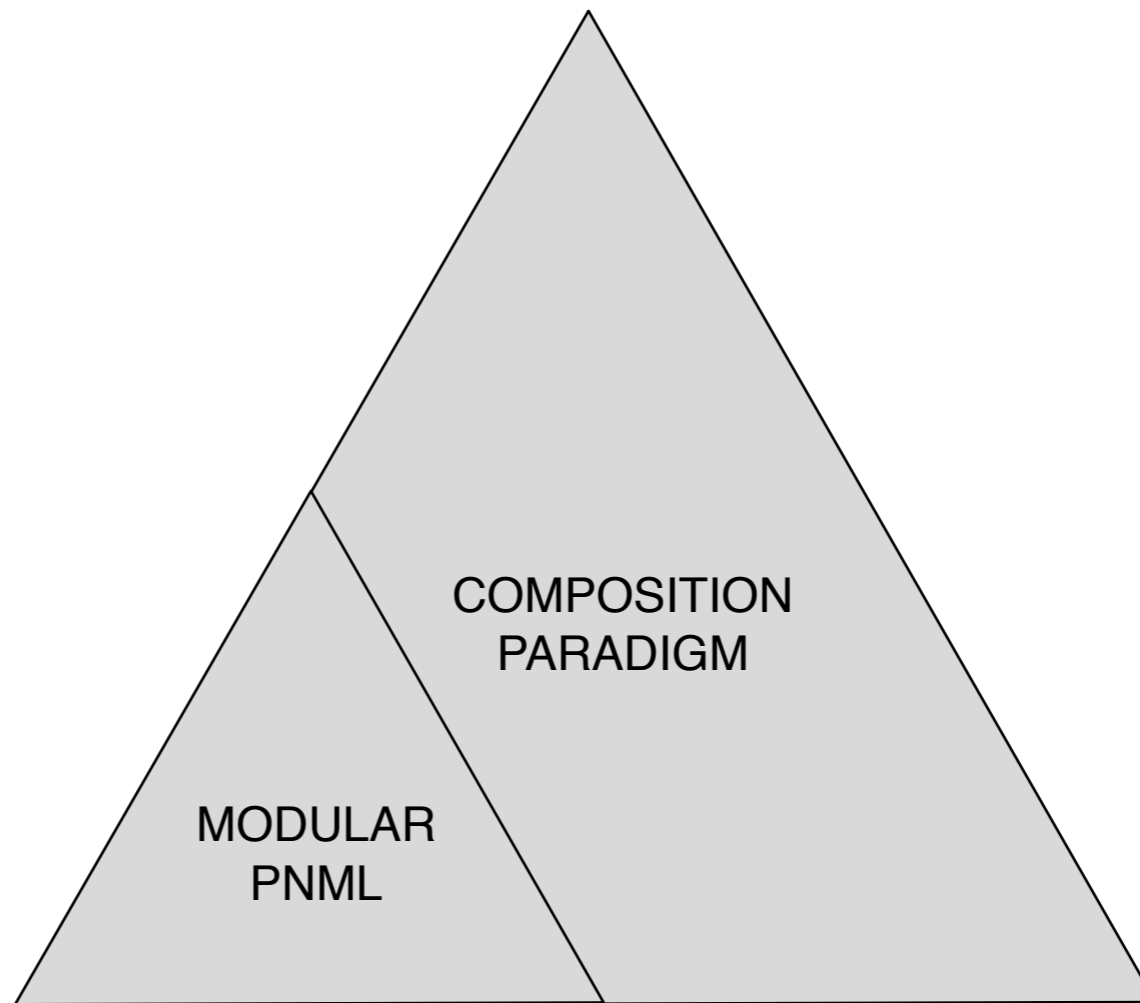

Enrich the current definitions

Parameterized interface elements

Duplication of service calls

Change the composition paradigm

Enrich the current definitions

Parameterized interface elements

Duplication of service calls

Change the composition paradigm

Non-deterministic compositions

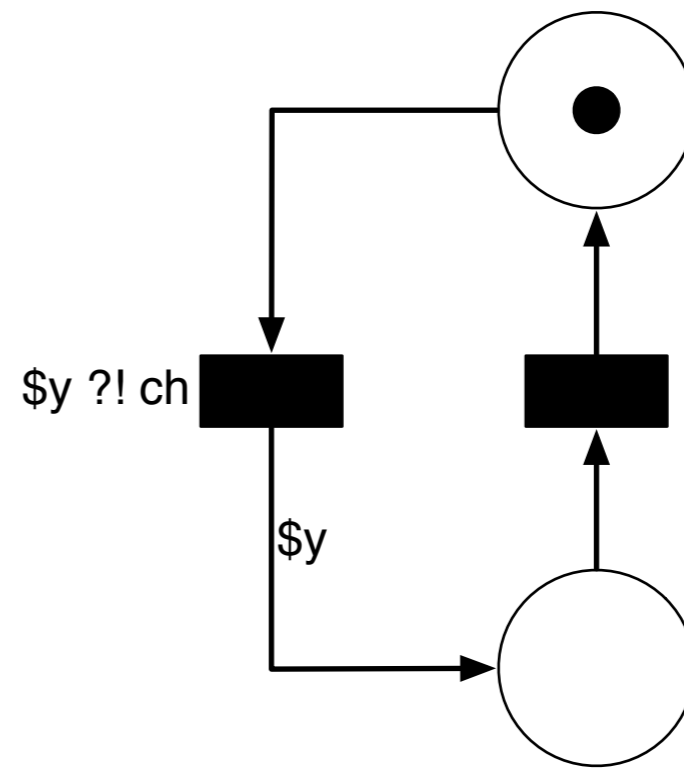
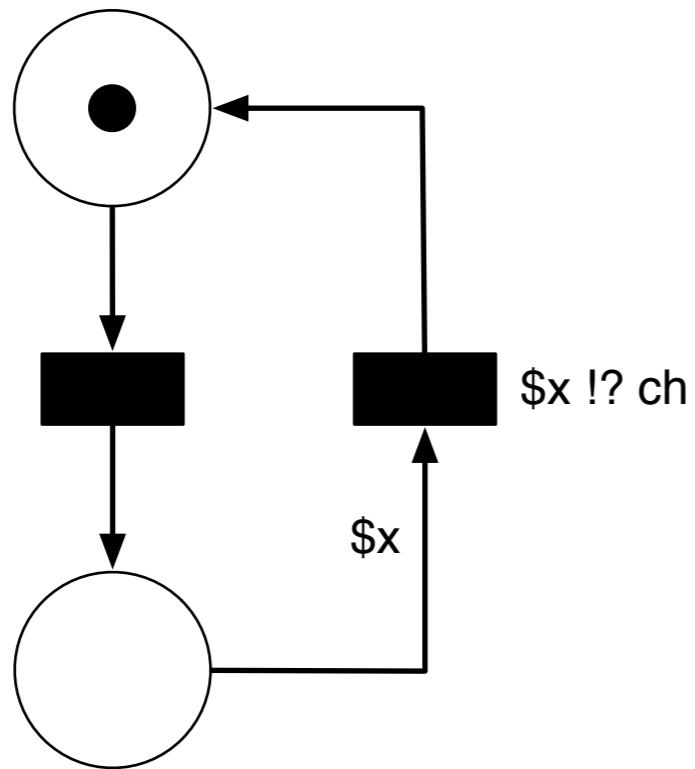
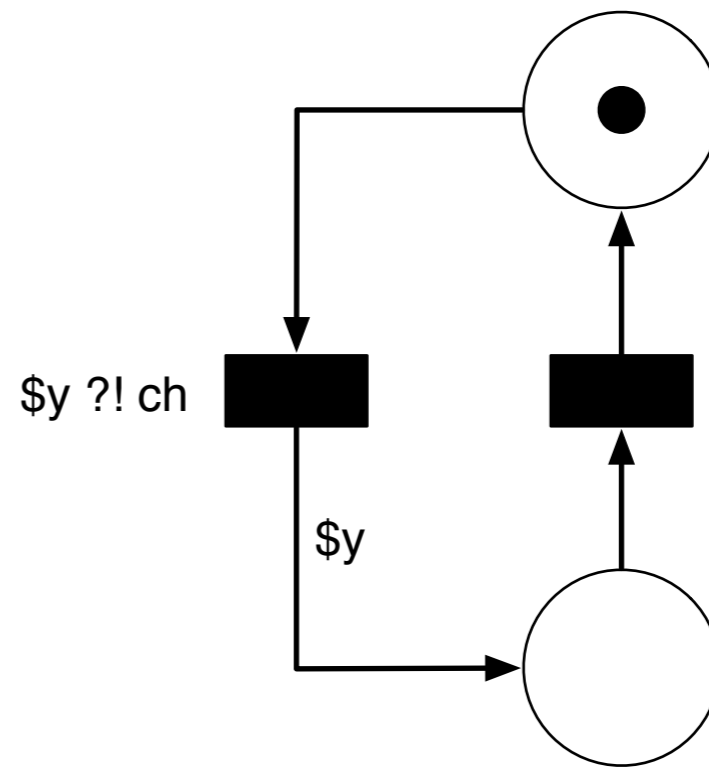
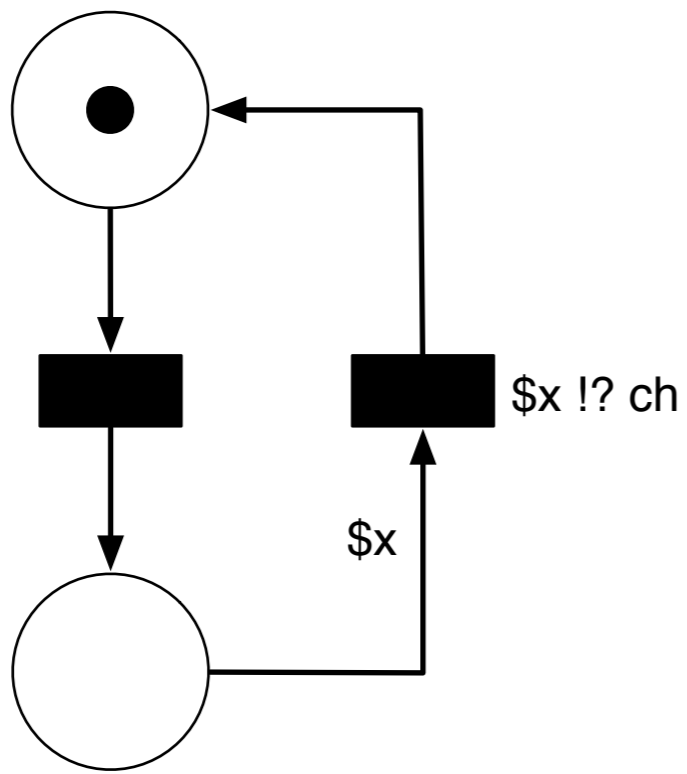

Christensen, Damgaard Hansen, 1994,



Coloured Petri Nets Extended with Channels for Synchronous Communication

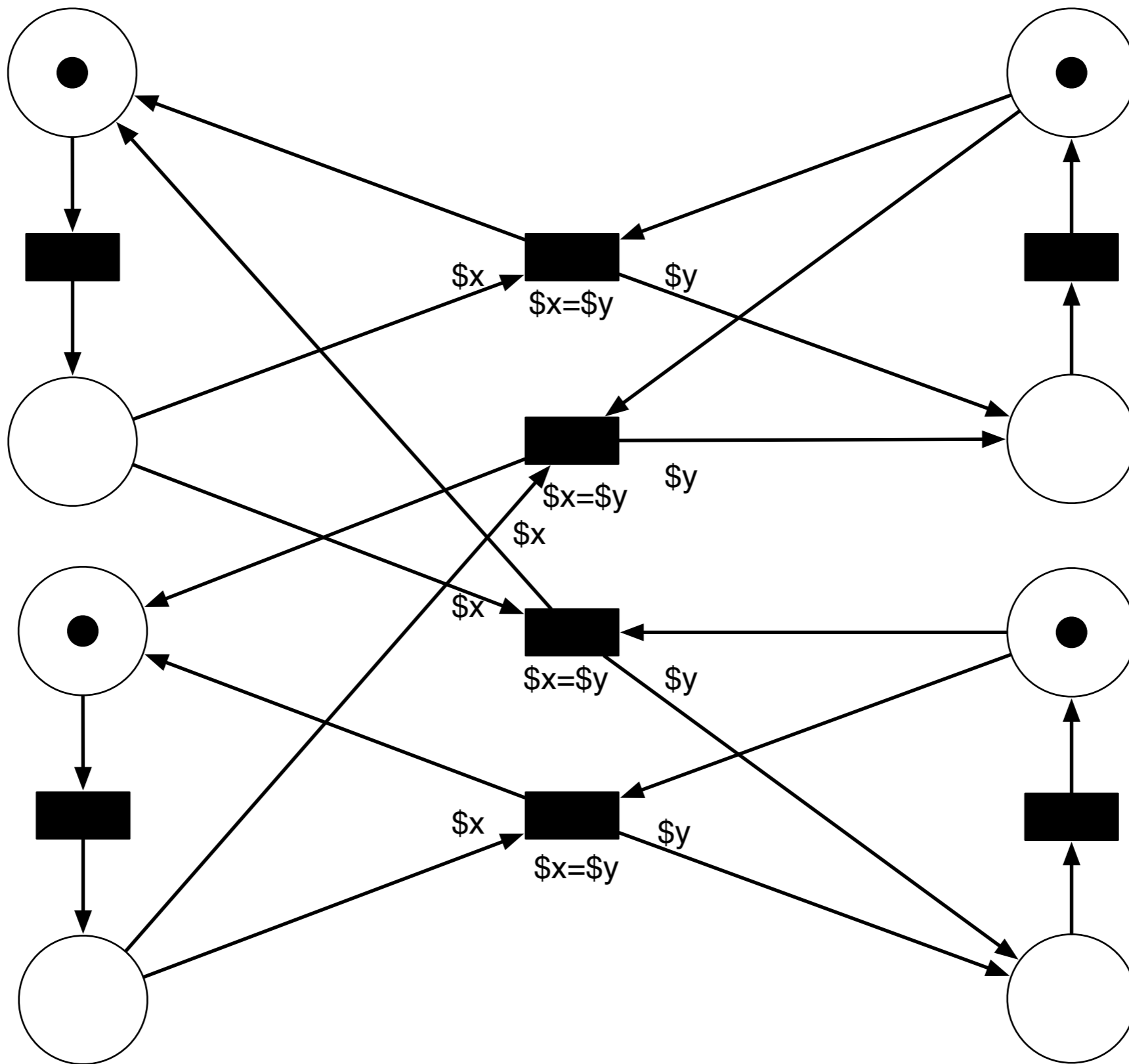

Christensen, Damgaard Hansen, 1994,



Coloured Petri Nets Extended with Channels for Synchronous Communication

Enrich the current definitions

Parameterized interface elements

Duplication of service calls

Change the composition paradigm

Non-deterministic compositions

Enrich the current definitions

Parameterized interface elements

Duplication of service calls

Change the composition paradigm

Non-deterministic compositions

Parameter-based compositions

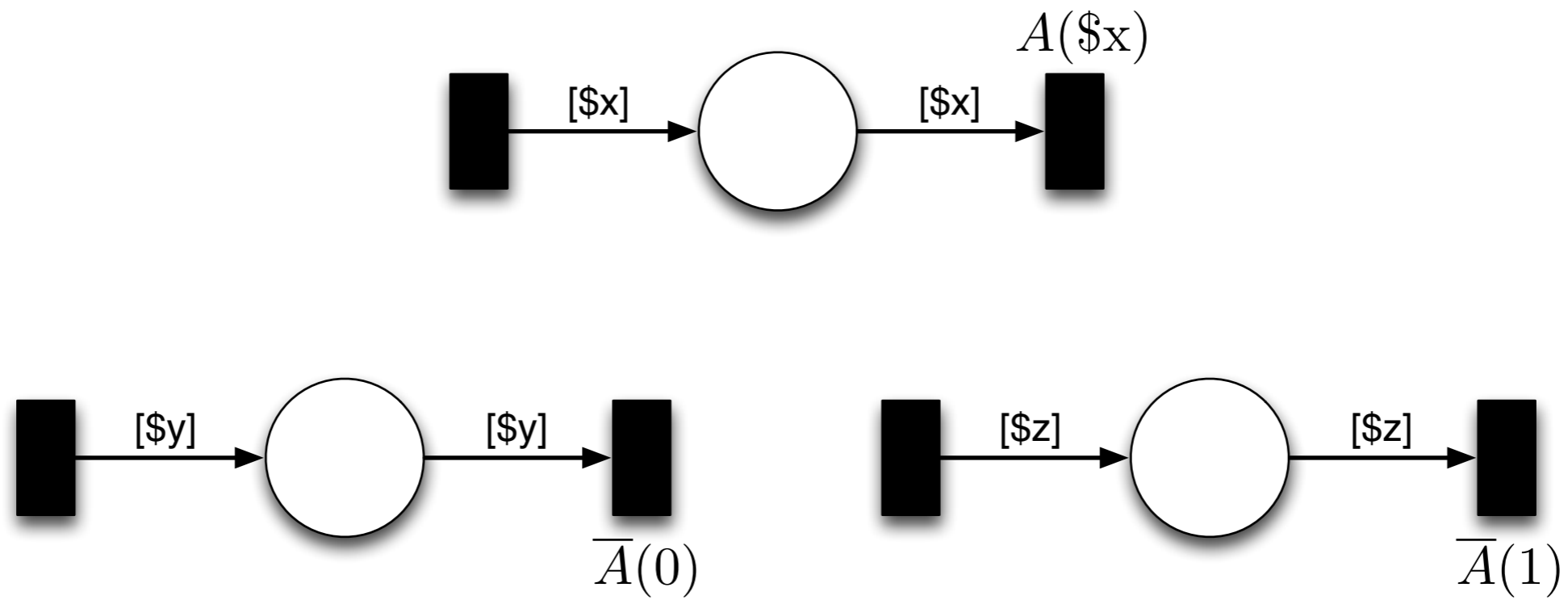

Lilius, 1996,
OB(PN)2: An Object Based Petri Nets Programming Notation

Enrich the current definitions

- Parameterized interface elements

- Duplication of service calls

Change the composition paradigm

- Non-deterministic compositions

- Parameter-based compositions

Enrich the current definitions

- Parameterized interface elements

- Duplication of service calls

Change the composition paradigm

- Non-deterministic compositions

- Parameter-based compositions

- Priority-based compositions

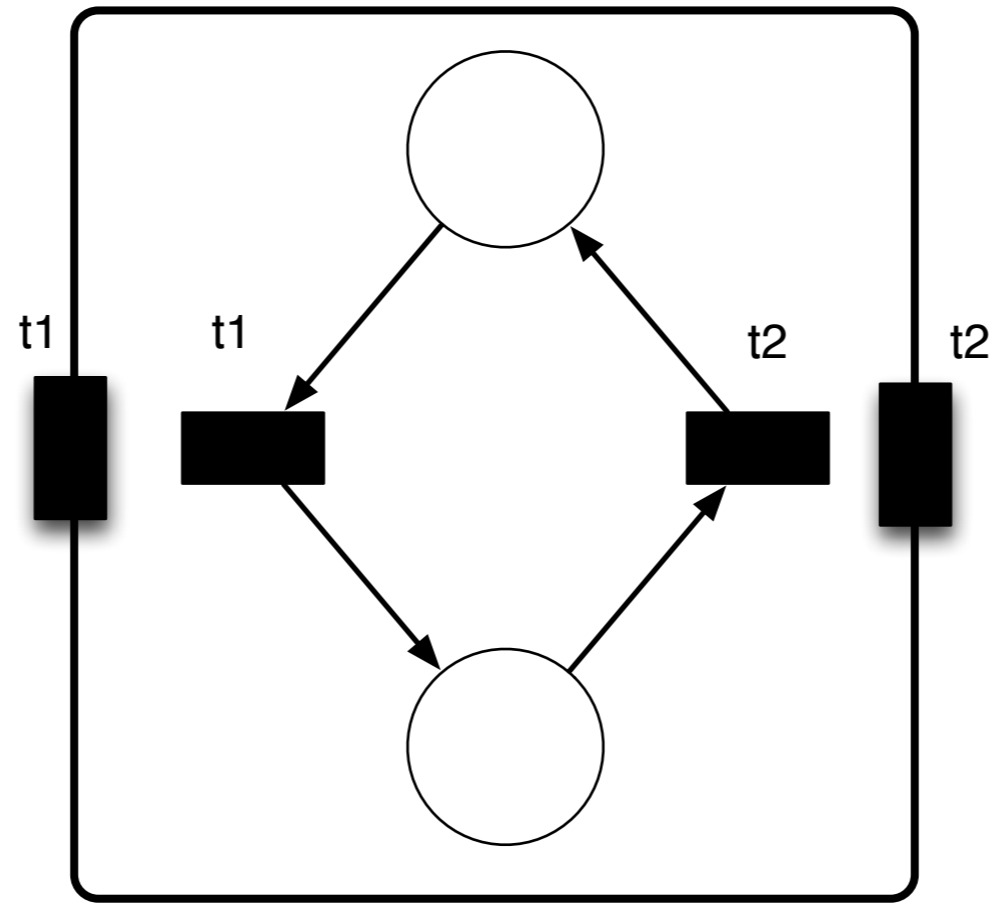

$t1 > t2$

Bozga, Sfyrla, Sifakis, 2009,
Modeling Synchronous Systems in BIP

Enrich the current definitions

- Parameterized interface elements

- Duplication of service calls

Change the composition paradigm

- Non-deterministic compositions

- Parameter-based compositions

- Priority-based compositions

Enrich the current definitions

Parameterized interface elements

Duplication of service calls

Change the composition paradigm

Non-deterministic compositions

Parameter-based compositions

Priority-based compositions

Complex
synchronizations

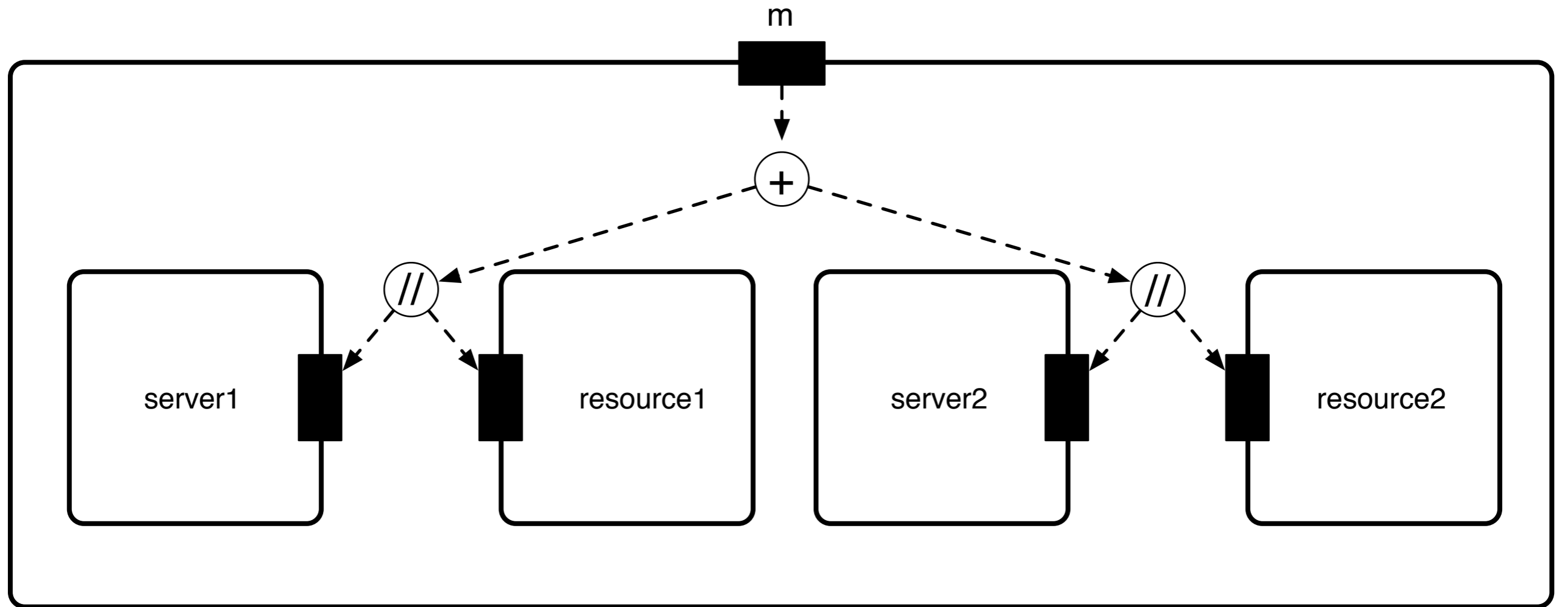

Biberstein, Buchs, Guelfi, 2001,
Object-Oriented Nets with Algebraic Specifications: The CO-OPN/2 Formalism

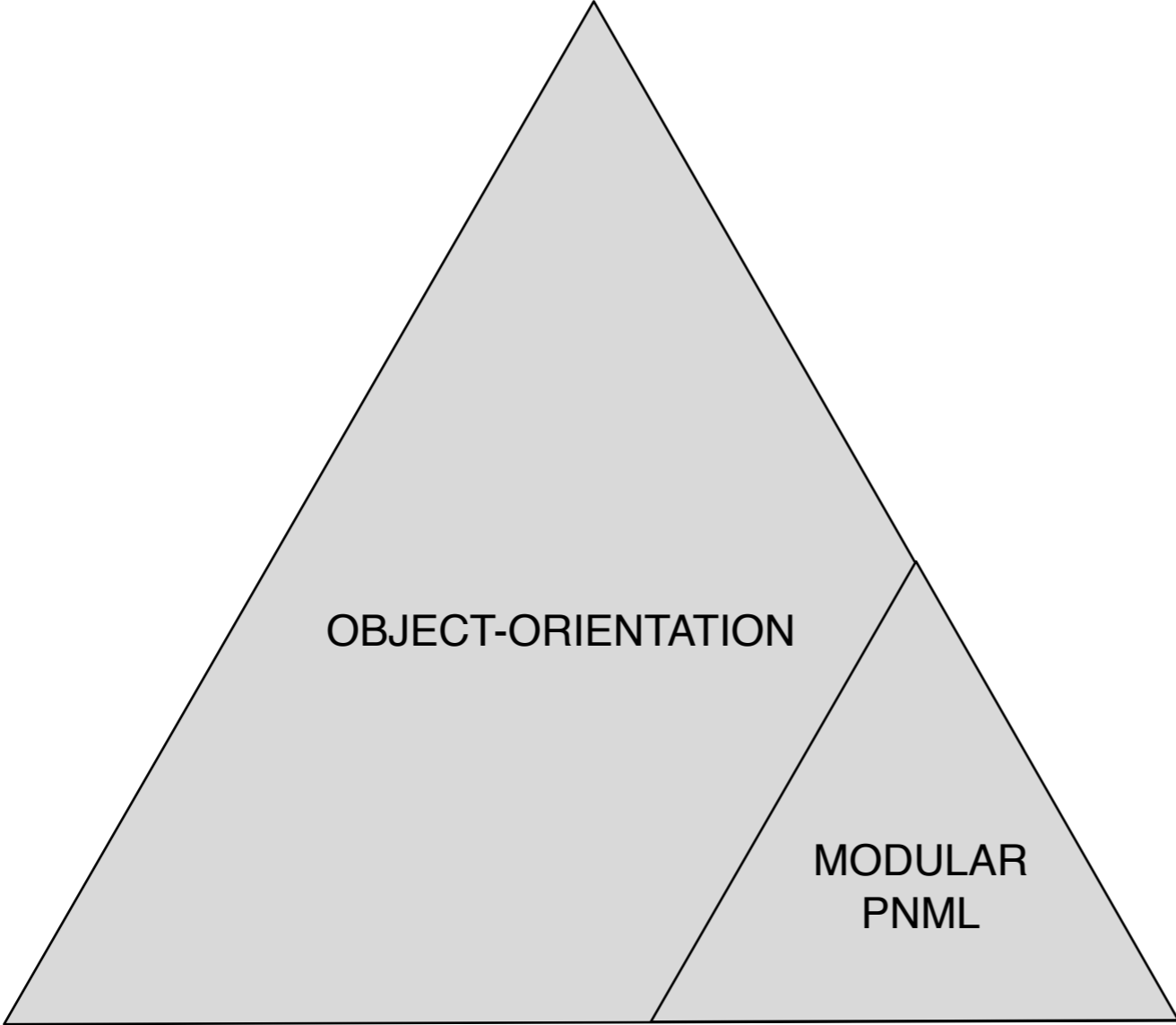

Enrich the current definitions

Parameterized interface elements

Duplication of service calls

Change the composition paradigm

Non-deterministic compositions

Parameter-based compositions

Priority-based compositions

} Complex
synchronizations

Add object-orientation

Enrich the current definitions

Parameterized interface elements

Duplication of service calls

Change the composition paradigm

Non-deterministic compositions

Parameter-based compositions

Priority-based compositions

} Complex
synchronizations

Add object-orientation

Dynamic instantiation

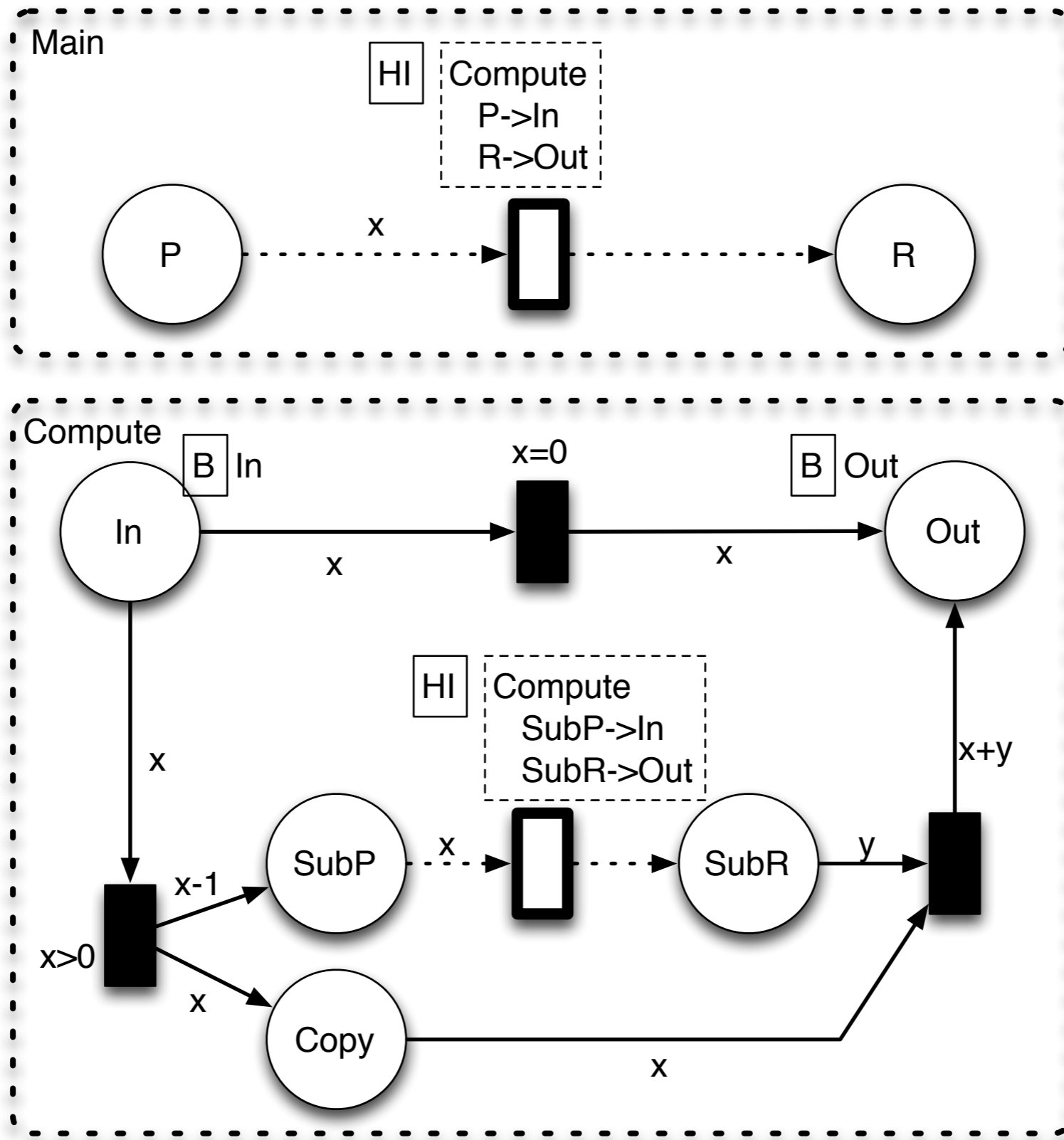

Hubert, Jensen, Shapiro, 1991
 ★ Hierarchies in Coloured Petri Nets

Enrich the current definitions

Parameterized interface elements

Duplication of service calls

Change the composition paradigm

Non-deterministic compositions

Parameter-based compositions

Priority-based compositions

} Complex
synchronizations

Add object-orientation

Dynamic instantiation

Enrich the current definitions

Parameterized interface elements

Duplication of service calls

Change the composition paradigm

Non-deterministic compositions

Parameter-based compositions

Priority-based compositions

} Complex
synchronizations

Add object-orientation

Dynamic instantiation

Object-orientation

Enrich the current definitions

Parameterized interface elements

Duplication of service calls

Change the composition paradigm

Non-deterministic compositions

Parameter-based compositions

Priority-based compositions

} Complex
synchronizations

Add object-orientation

Dynamic instantiation

Object-orientation

} Nets within nets

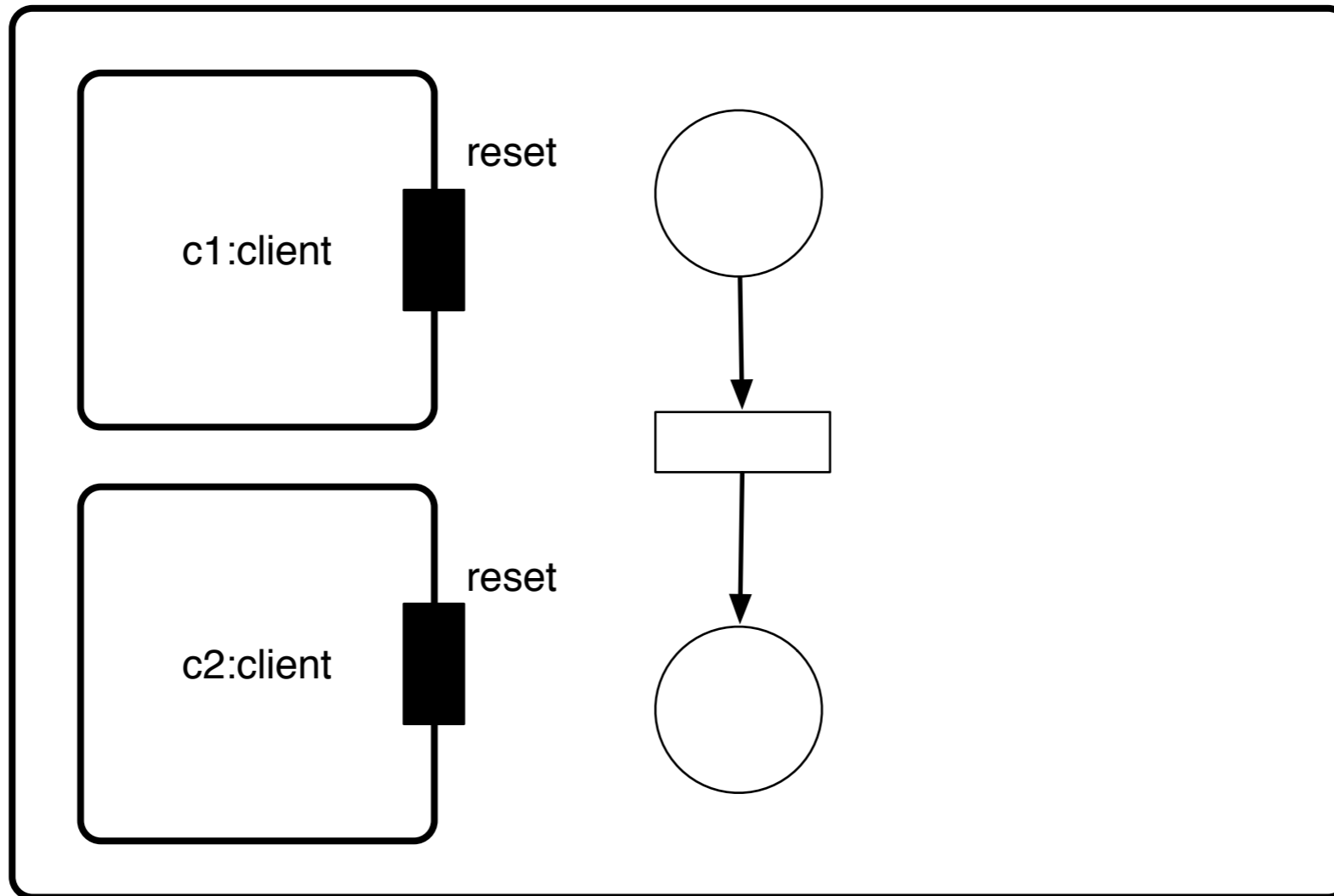

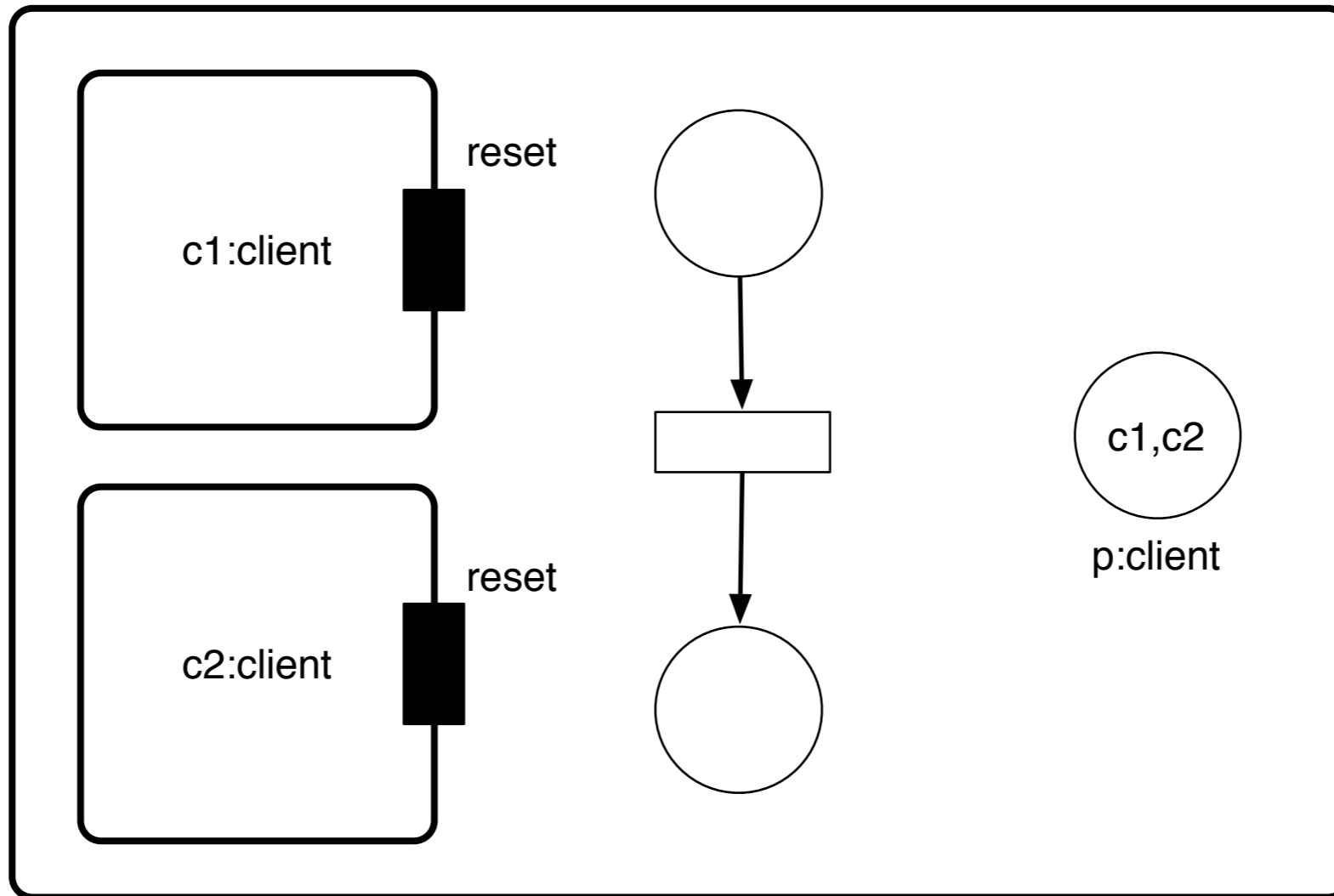

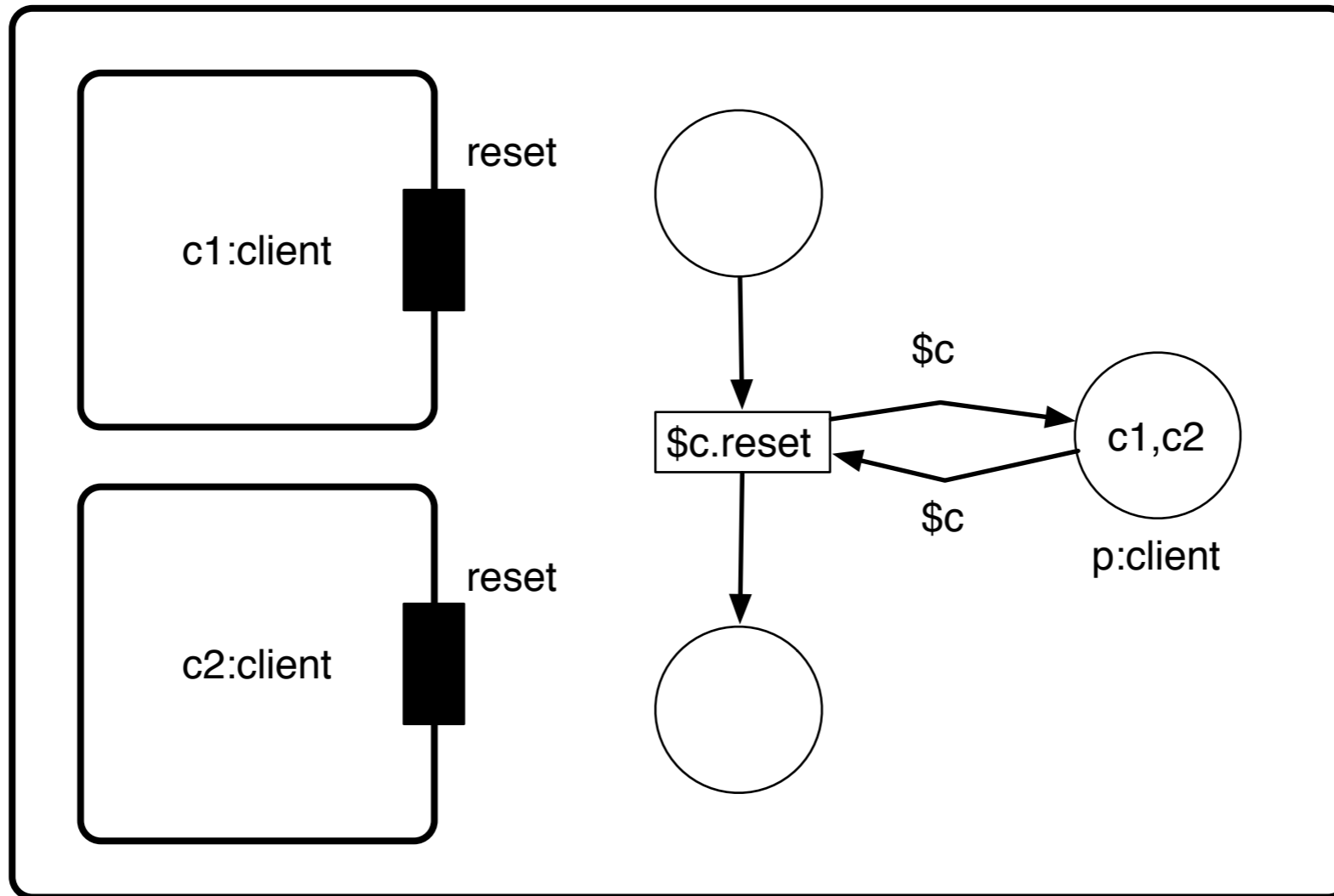

Nets within nets

CO-OPN

OCP-nets

Communicating Object Petri nets

CLOWN

CoOperative objects

Object Petri nets

...

Nets within nets

Outline



Scope

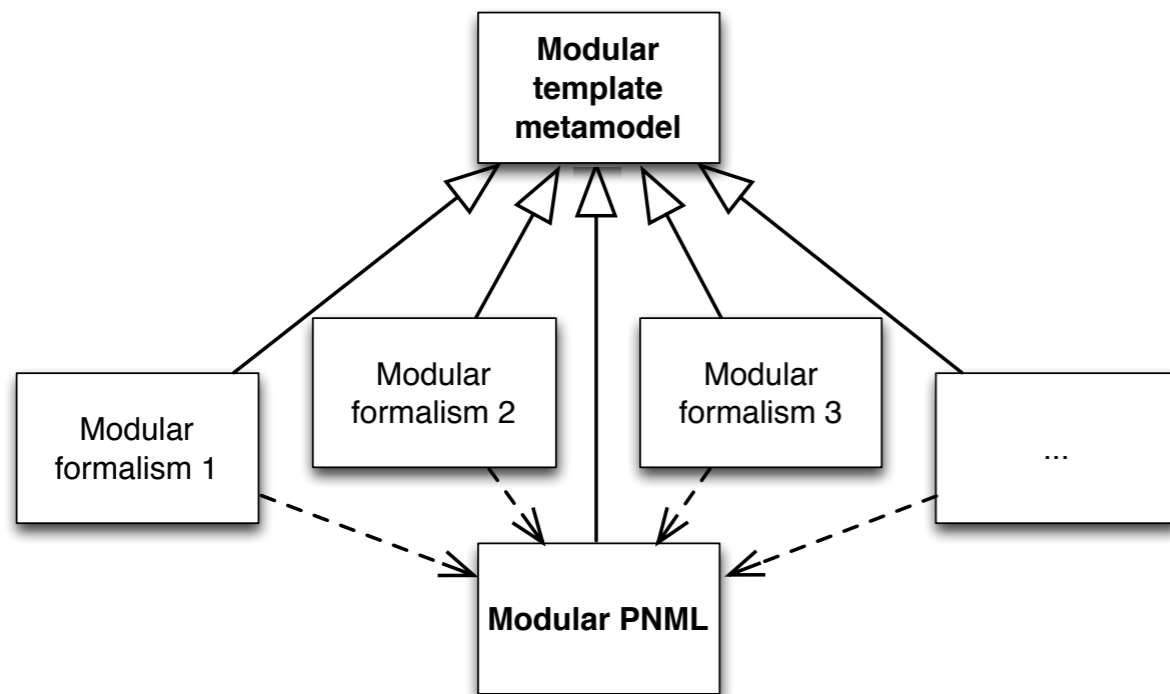
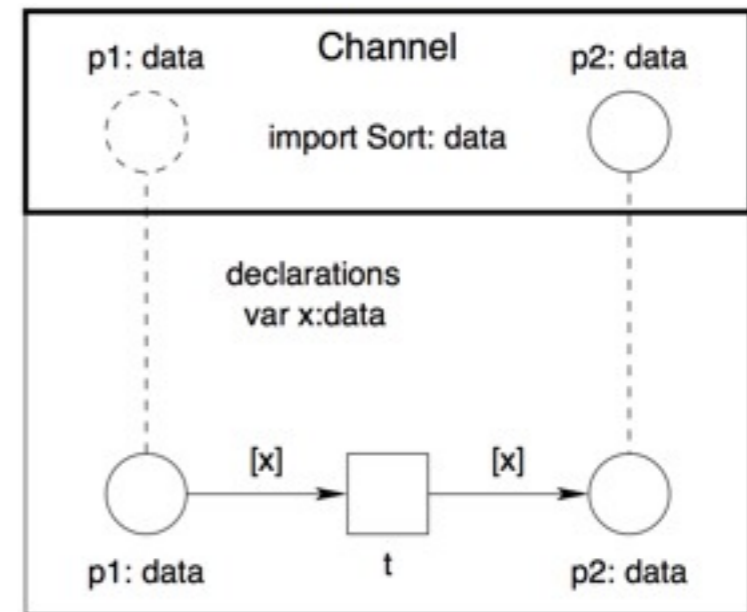

Methodology

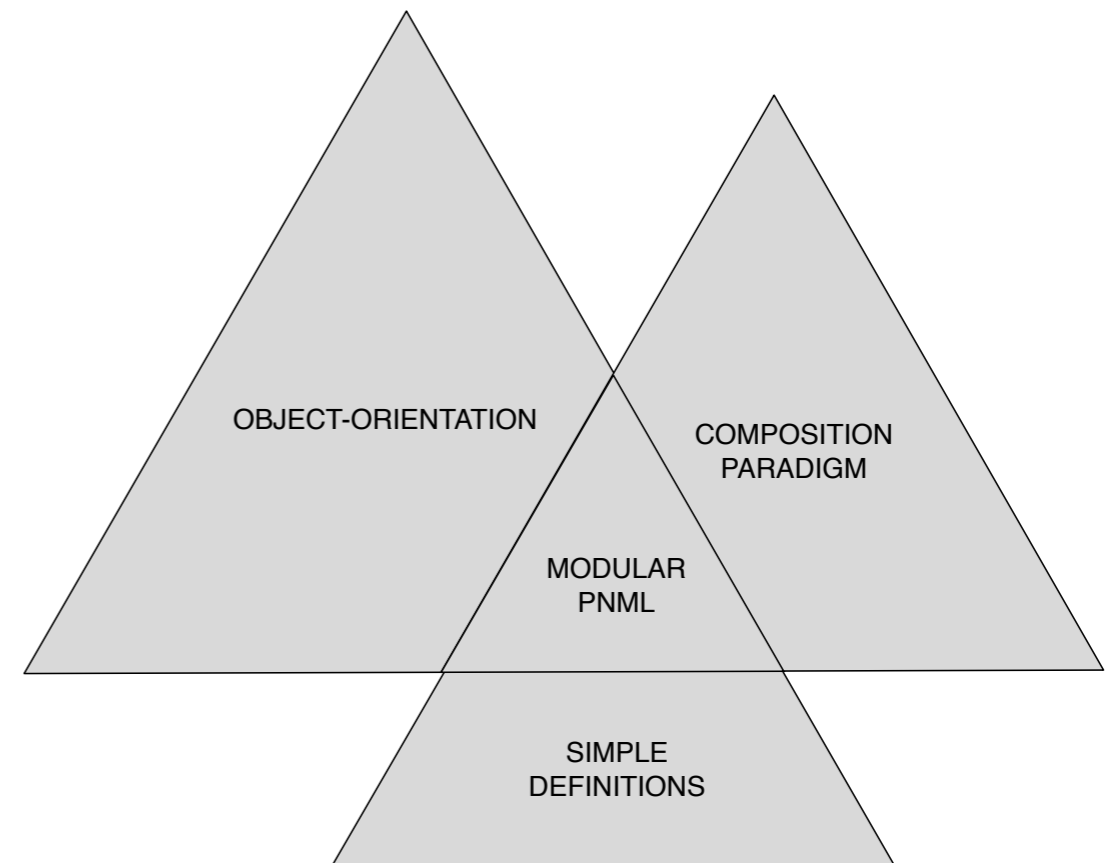

Extensions

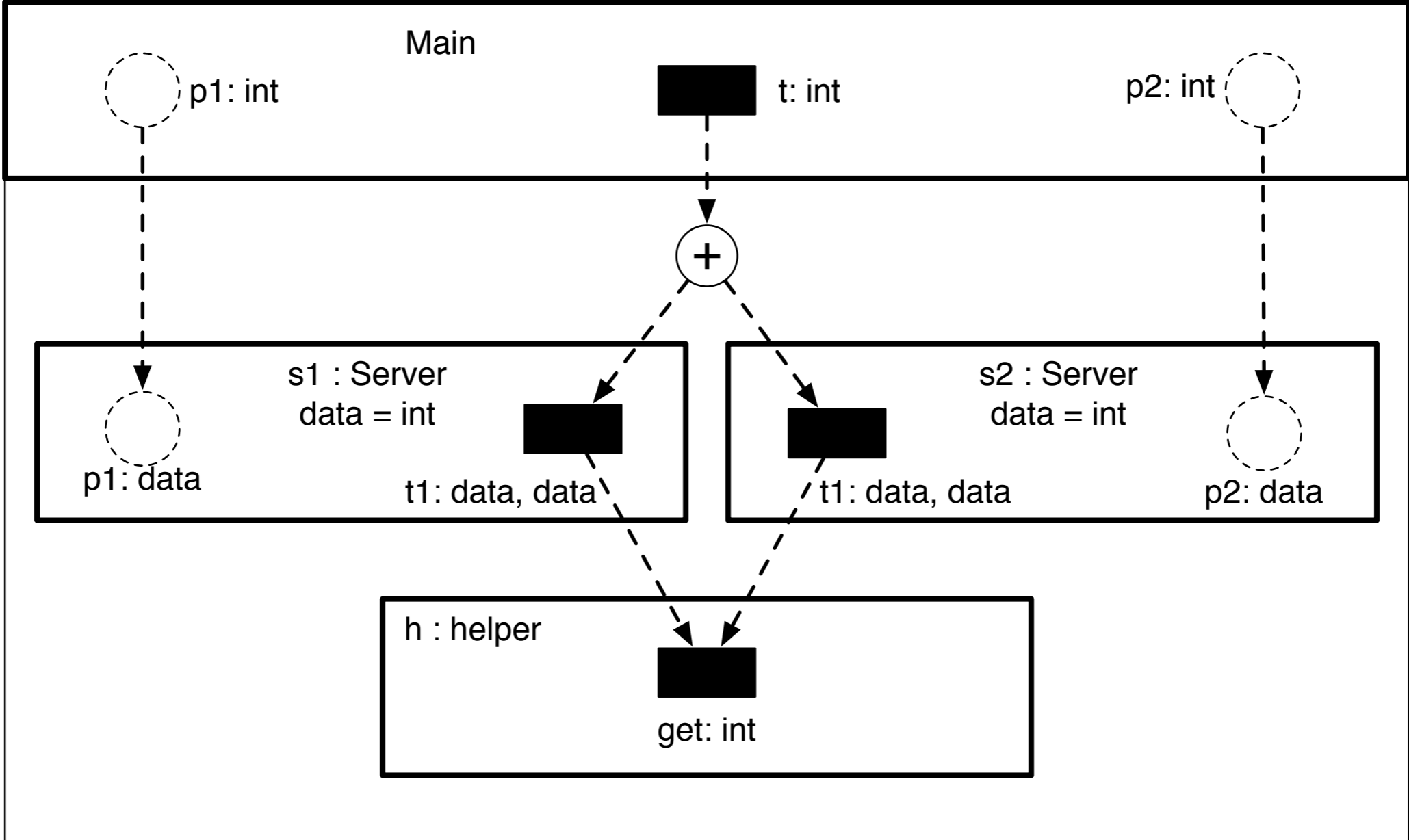

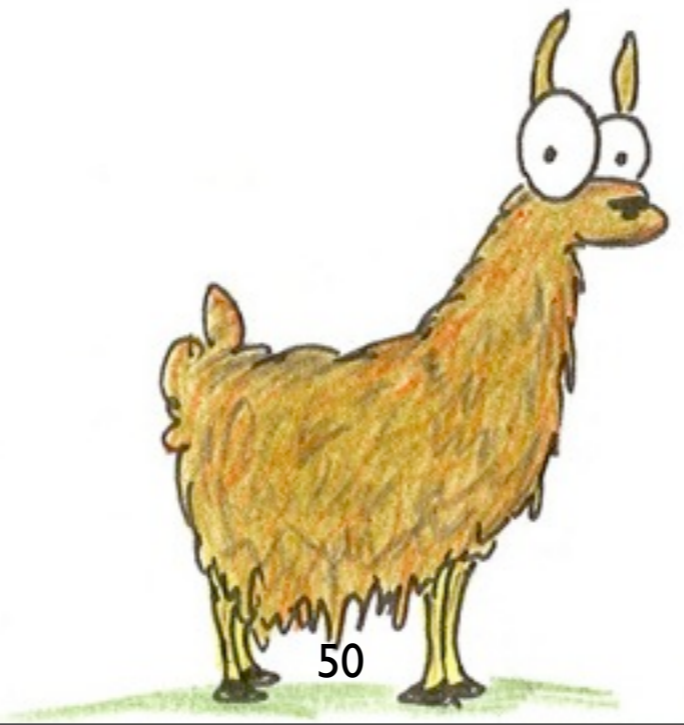
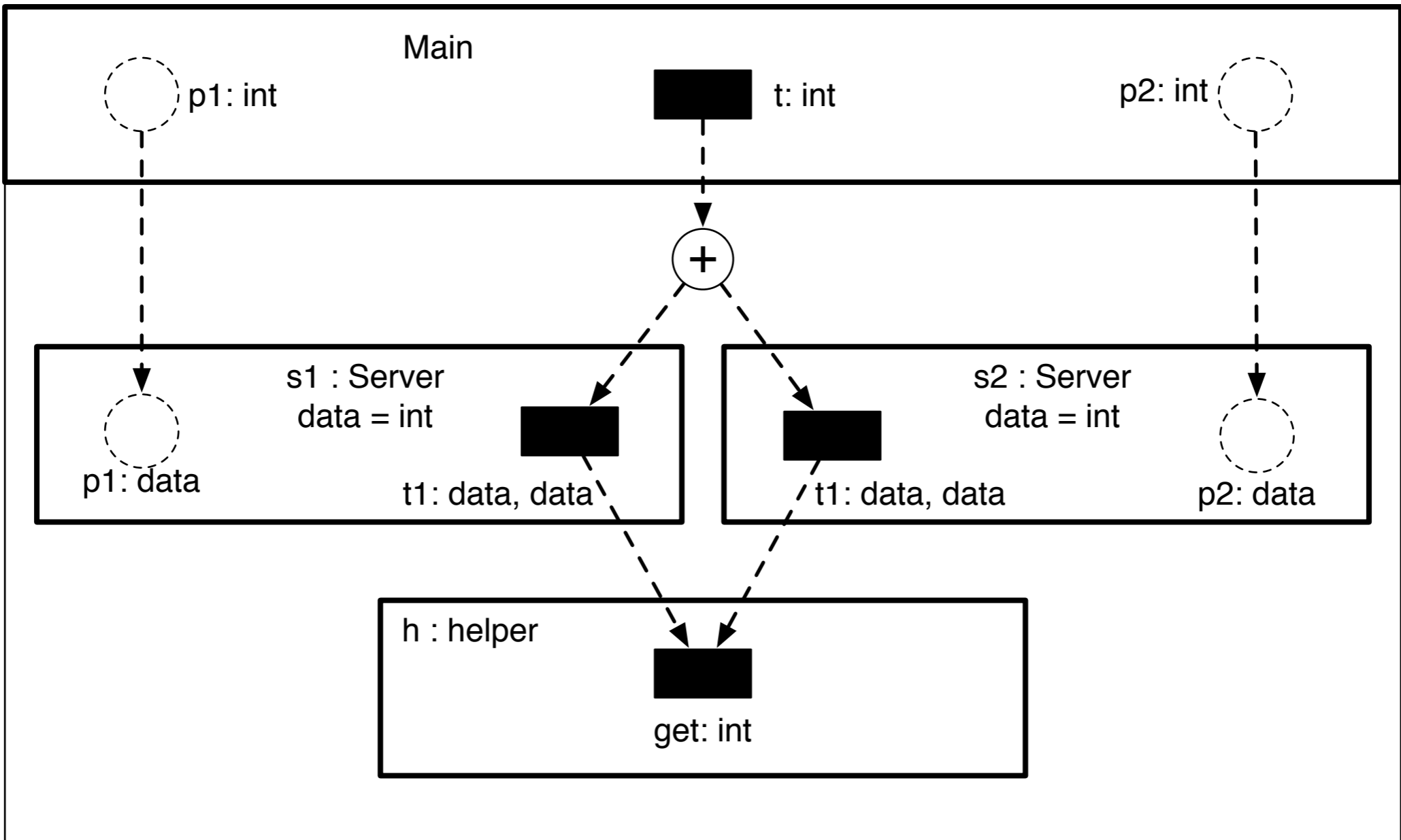

HOW STANDARDS PROLIFERATE:
(SEE: A/C CHARGERS, CHARACTER ENCODINGS, INSTANT MESSAGING, ETC)



xkcd.com